

Lift Truck Safety

**For the Fruit and Vegetable Preserving
and Specialty Foods Manufacturing
Industry**

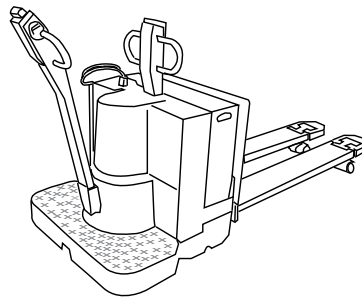
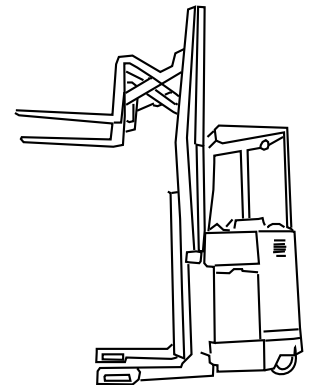
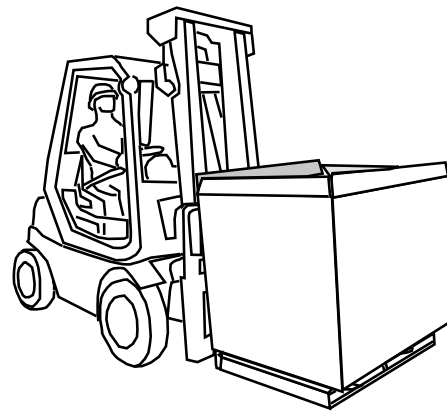

KSTATE Research and
Kansas State University Extension

*“Knowledge
for Life”*

Lift Truck Safety

Contents

Introduction	
What's Inside?	3
Lesson 1	
Take Control of Your Own Safety.....	4
Lesson 2	
Prepare For Safe Operation.....	8
Lesson 3	
Avoid Rollover Accidents.....	15
Lesson 4	
Avoid Runover Accidents.....	20
Lesson 5	
Prevent Crushing Accidents	23
Lesson 6	
Prevent Other Injuries and Illnesses.....	28
Conclusion	33
Quiz Yourself Solutions	35

Written by:

Mitch Ricketts, Coordinator, Health, Safety and Environmental Quality, K-State Research and Extension

Pamela Riemenschneider, Information specialist

Disclaimer

This material was produced under grant number 46 G4-HT13 from the Occupational Safety and Health Administration, U.S. Department of Labor. It does not necessarily reflect the views or policies of the U.S. Department of Labor, nor does mention of trade names, commercial products, or organizations imply endorsement by the U.S. government.

This booklet was produced by K-State Research and Extension, Kansas State University, Manhattan, Kansas.

The information in this publication has been compiled from a variety of sources believed to be reliable and to represent the best current opinion on the subject. However, neither K-State Research and Extension nor its authors guarantee accuracy or completeness of any information contained in this publication, and neither K-State Research and Extension or its authors shall be responsible for any errors, omissions, or damages arising out of the use of this information. Additional safety measures may be required under particular circumstances.

What's Inside?

This booklet teaches important safety practices to follow when using a lift truck.

Safety tips, along with real accident reports, have been combined to give you a better understanding of the risks associated with this type of work.

Use this booklet along with hands-on safety training and the equipment operator's manual.

Lesson 1

Objectives

1. Name the most common types of lift truck accidents.
2. Identify safety signs related to lift truck use.

Take Control of Your Own Safety

Greatest Dangers

The most commonly reported causes of serious injury and death while using a lift truck are:

1. Rollovers

Accident Report Employee Killed in Lift Truck Rollover

Summary of OSHA Accident Inspection 170613830

An employee was driving a lift truck through a warehouse. The lift truck hit a ledge while making a turn. The lift truck rolled onto its side. The employee tried to jump clear but was caught under the lift truck's overhead guard. He was not wearing his safety belt and died from his injuries.



Always wear your safety belt; watch out for ramps, ledges and other obstacles.

2. Runovers

Accident Report Pedestrian Struck and Killed by Lift Truck

Summary of OSHA Accident Inspection 014385595

A lift truck operator was transporting a pallet load of materials. The load was blocking the operator's view and he could not see a co-worker walking ahead. He struck and killed his coworker.



Drive in reverse if you must transport a load that blocks your view. If you cannot drive in reverse, have a coworker guide you.

3. Crushing and Collision Accidents

Accident Report Employee's Foot Crushed By Forks

Summary of OSHA Accident Inspection 111897286

An employee was standing with his left foot on the mast of a lift truck. He was spraying lubricant while operating the lift controls with his right foot. When the forks lowered, his foot was crushed between the carriage and the mast.



Never operate the controls of a lift truck from anywhere but inside the operator's area.

Accident Report Employee Killed in Lift Truck Collision

Summary of OSHA Accident Inspection 170667158

An employee was driving a lift truck and swerved to avoid an obstacle. He lost control of his vehicle and collided with another lift truck. The collision caused a fork from the second lift truck to impale the thigh of the employee. The employee died from his injuries.



Always travel at safe speeds so you have time to avoid obstacles.

Help Yourself

Safe work habits are important. Here are three actions you can take to be safe on the job site:

1. Learn all you can

To prevent lift truck accidents, read and follow directions in the equipment operator's manual. Pay attention to safety instructions in the manual and warning labels you see on the equipment. If you have questions, stop and ask your supervisor before you continue.

2. Concentrate on working safely

Sometimes you may be tempted to take risky shortcuts. Remember that an accident can leave you permanently injured or cut your life short. For your safety and the safety of those around you, do not take unnecessary risks. No deadline is so pressing you can't take the time to do your work safely.

3. Additional precautions

Do not operate machinery if you are fatigued or have taken drugs or alcohol. If you are on medication, discuss with your doctor or pharmacist if you are capable of safely operating machinery.

Operator Certification

The Occupational Safety and Health Administration requires employers to provide training and certification for all powered industrial truck operators. Operators are required to be at least 18 or older and must be certified before driving powered industrial trucks. Direct supervision of operators in training is required at all times.

Operator certification must be repeated every three years.

Refresher training should be performed if an operator is observed using unsafe practices, has a near-miss accident, is assigned to a different type of truck they have not previously used, or if conditions in the workplace change in a way that could affect safe operation of the truck.

This book can be used as a part of a certification training program, in conjunction with your employer's specific operating policies, procedures and hands-on performance testing.

It is a violation of federal law for anyone under the age of 18 to operate a lift truck.

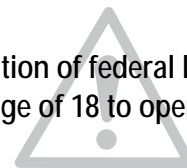

Locate the Data Plate

Every lift truck is equipped with a data plate that gives important information about the truck's lifting capacity and weight limit. If your truck's data plate cannot be read due to wear or is missing, tell your supervisor. A new data plate must be obtained from the truck's manufacturer.

Sample Data Plate

MODEL NO.		TYPE	
SERIAL NO.			
ATTACHMENTS			
LOAD		CAPACITY WITH ATTACH. LISTED ABOVE OR WITH FORKS--UPRIGHTS VERTICAL	
C	A	LBS	A B C
FLOOR			
APPROX. WT. ALL TRUCKS			
APPROX. WT. ELECTRICS ONLY			
BATTERY WT.			
BATTERY			
CAPACITY			
FOR OTHER CAPACITIES - CONSULT MANUFACTURER AS RELEASED FROM FACTORY THIS TRUCK MEETS THE DESIGN SPECIFICATIONS ESTABLISHED IN AMERICAN NATIONAL STANDARD FOR POWERED INDUSTRIAL TRUCKS			

The data plate gives you the following information:

- ▶ The truck's model and serial number.
- ▶ The truck's type designation. This is important if you will be working in a hazardous area.
- ▶ The attachment description. This will tell the weight of the attachments and truck's capacity with attachments.
- ▶ The capacity rating, load center, and lifting height. This shows the capacity of the truck in relation to the weight of the load and the height it is lifted.
- ▶ The truck's weight, both loaded and unloaded. This is important so you will know when it is safe to work on elevators, trucks, decks, docks and floors.

NOTICE:

If the truck is modified or has an attachment not included on the data plate, you must get approval for the modifications in writing from the manufacturer and a new data plate with the modified information.

Safety Messages and Signs

Manufacturers put important safety messages on lift truck equipment and in the operator's manual. It is critical to read, understand and follow safety messages.

The triangle shape is the symbol for caution. The exclamation mark in the center means *Pay Attention*. In some instances, the triangle-shaped sign will show a picture. Other times, words explain why the sign is used.

Many safety messages use the words *Caution*, *Warning* and *Danger* to get your attention. Following are safety messages and their meanings. Each of these signs will have a written message, and perhaps a picture, about an unsafe condition. Caution signs are yellow, warning signs are orange and danger signs are red.

CAUTION means you need to be careful. Follow the directions on the sign or you could get hurt.

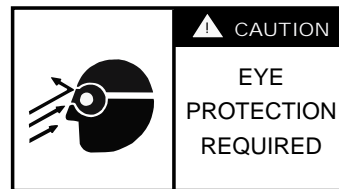

WARNING is more serious and means you need to follow the directions on the sign or you could be seriously injured or killed.



DANGER is the most serious safety message. If you don't follow the directions, you will be seriously injured or killed.



Images displayed in the caution, warning and danger boxes have been recreated from images taken with permission from ASAE S441.4, FEB04, Safety Signs.

Quiz Yourself

Answers can be found on page 35.

Use the list of words to fill in the blanks:

rollover
older
fatigued
data plate

1. If the _____ is no longer readable or is missing, get a new one from the manufacturer.
2. Do not operate a lift truck if you are _____ or under the influence of alcohol or drugs.
3. A _____ is the most commonly reported type of serious lift truck accident.
4. You must be 18 years of age or _____ to legally operate a lift truck.

Match the safety image with its meaning:

A. High Pressure Hydraulics



B. Overhead Crushing Hazard

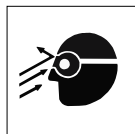

C. Eye Protection Required



Lesson 2

Objectives

1. Describe how to inspect a lift truck before operation.
2. Discuss safe startup, operation and shutdown procedures.

Prepare for Safe Operation

Types of Lift Trucks

Lift trucks are also called powered industrial trucks or forklifts. They are classified by the way they are powered—gasoline, diesel, LP-gas, electric or combination power source—as well as how they are operated. Make sure the type of lift truck you are operating is appropriate for your operating conditions.

Sit-down Rider Lift Trucks are the most common lift truck.



They use gasoline, LP-gas, diesel, batteries or a combination of these power sources. If you will be working around flammables, make sure your lift truck's power source is approved for your working conditions.

Stand-up Rider Lift Trucks are commonly used in narrow aisles, where other trucks cannot maneuver. They are commonly powered by electric motors. Often, a stand-up rider truck is equipped with forks that can extend horizontally and/or reach around corners.

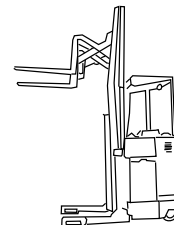

High-lift Order Pickers have a platform to raise the operator to the level of stored materials. Operators stand on the platform to pick from pallets without having to bring the pallet to the ground level. High-lift order pickers are usually powered by electric motors and equipped with safety restraints to keep the operator from falling.

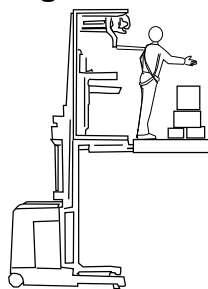

High-lift Pallet Jacks transport and store pallets, and are powered by an electric motor. They are capable of lifting pallets for storage. Although they can be equipped with a platform for the operator to ride on, they are most commonly used with an operator walking to the side while using the controls.

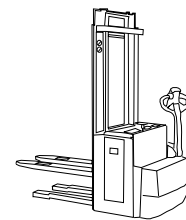

Low-lift Pallet Jacks are used to transport pallets. The forks only raise a load high enough for transport. They are powered by electric motors. They can be equipped with an operator's platform for long distance travel, but are most commonly driven with an operator on the side of the controls, walking while facing the direction of travel.

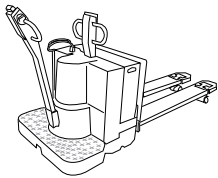

Rough Terrain Lift Trucks are used for heavy-duty transport outside in rougher conditions than would be present on a warehouse floor. Rough terrain lift trucks are usually diesel or gasoline powered and can sometimes be equipped with an enclosed operator's compartment.

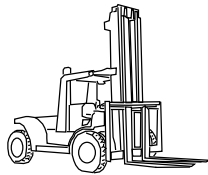

Pre-operation Inspection

Before each shift you must perform an inspection, regardless of what type of lift truck you are operating. If your company has more than one shift in a day, the inspection must be performed before every shift.

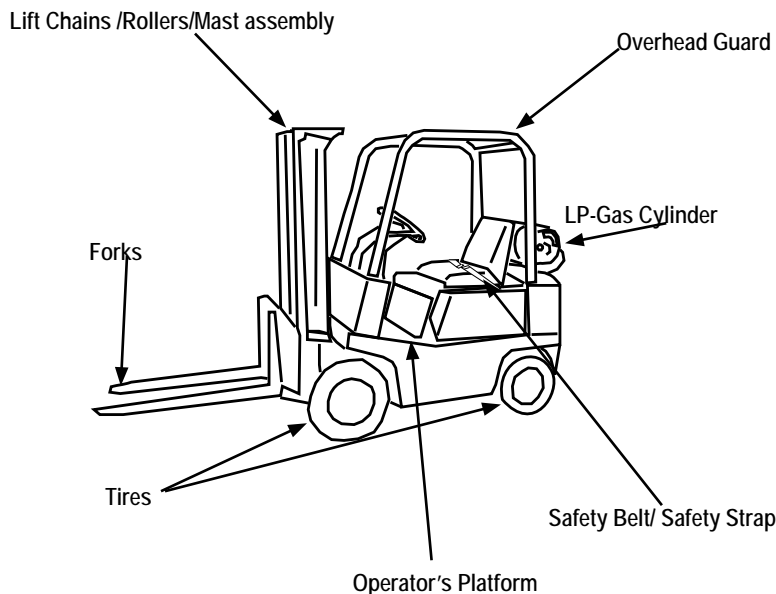

Tires

The tires should be properly inflated or have the proper ballast (if so equipped) and should not be excessively worn. They should have no large cuts that go completely around the tire. There should not be large pieces of rubber separated from the rim and all lugs should be in place.

Overhead Guard

The overhead guard should not have broken welds, or damaged or bent rails.

Daily Operation Checklist

- Tires
 - Proper pressure, ballast?
 - No cracks, excessive tread wear?
- Overhead Guard
 - No broken welds?
 - No damaged or bent rails?
- Safety Belt/Safety Strap
 - No fray or excessive wear?
 - Holds securely?
- Forks
 - Mismatched, cracked, welded or bent?
 - Free of oil or other slippery substances?
- Mast Assembly/Lift Rollers/Chains
 - No broken welds, missing stops or excessive wear?
 - No rust, smooth operation?
- Fluids
 - No puddles under vehicle?
 - No drips, levels are all normal?
- LP-Gas
 - Hoses in good condition?
 - No gas smell?
- Battery
 - Cables intact, insulation not damaged?
 - Caps and terminal covers in place?
- Operator's Platform
 - No spills or debris?
 - Non-skid surface not worn?
- Horn/Lights/Mirrors
 - Horn sounds?
 - Lights operational?
 - Mirrors clean and free of cracks?
- Data Plate
 - Present and readable?
 - Truck rated for task/job?
- Vehicle Performance
 - Controls are working properly?
 - Backup alarm sounds?
 - Brakes and steering OK?

Dress Appropriately

To protect yourself always:

- ▶ Wear form-fitting -- not baggy -- clothing. Baggy clothing could get caught in the moving parts.
- ▶ Tie back long hair to keep it from becoming caught in moving parts.
- ▶ Wear sturdy shoes and tie laces securely.

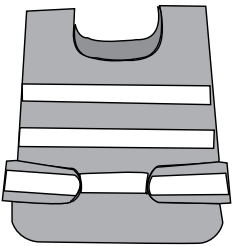
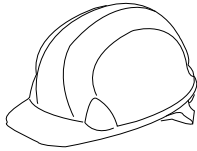

Depending on working conditions and your company's policies, you may also need:

- ▶ A hard hat.
- ▶ Eye protection.
- ▶ Hearing protection such as ear muffs or plugs (see guidelines, next page).
- ▶ Durable work gloves.
- ▶ A highly-visible, reflective work vest.
- ▶ A safety harness (high lift order pickers and personnel lifting platforms).

Safety Belt/Safety Strap

The safety belt (sit-down rider models) or safety strap (stand-up rider models) should not be frayed or excessively worn. The buckle should hold securely.

Forks

Since forks bear the weight of the loads you will be transporting, they should not have any cracks, be bent, mismatched or welded. They should be clean and free of excessive water or oil, which could cause a load to slip. Check to make sure they are secured to the carriage properly. If the forks are not original to the vehicle, consult the owner's manual for procedures for operating with replacement forks.

Mast Assembly and Lift Chains/Rollers

Make sure there are no cracks, broken welds, missing stops or excessive wear on the mast assembly. The lift chains and rollers should not be damaged. Make sure the chains are properly adjusted and lubricated.

Fluids

Check for obvious fluid leaks, engine oil, coolant, and transmission fluid. Look under the vehicle to make sure there are no puddles. Hydraulic hoses and connections should not be damaged.

LP-gas

The LP-gas tank should be secured and locked in place. The hose should not be damaged, kinked, pinched or bound and should be threaded squarely and tightly. There should not be a gas odor. If there is an odor, turn off the tank valve immediately and report it to your supervisor.

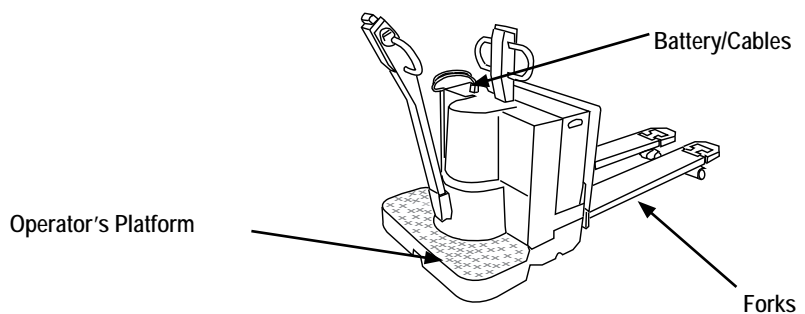

Battery

For battery-powered trucks, check to make sure that the cell caps and terminal covers are in place and that the cables are undamaged.

Operator's Platform

The operator's platform should be clean, dry and free of anything that could cause the operator to slip or fall. Clean up any spill, and make sure the non-skid surface is not excessively worn.

Horn/Lights/Mirrors

Check to make sure the lights (if equipped) and horn are operational. Mirrors should be clean and free of excessive cracks.

Data Plate

Check the vehicle's data plate to see if the vehicle is appropriate for the job. If the data plate is unreadable or missing tell your supervisor. Do not operate a lift truck without a data plate.

Vehicle Performance Inspection

Test all controls. Make sure the forks tilt, lift, lower and extend (if equipped) properly. They should lift smoothly without jerky movements. Put the vehicle in reverse to test the backup alarm. Test the brakes and steering.

Accident Report

Employee Killed After Lift Truck Brakes Fail

Summary of OSHA Accident Inspection 170220420

An employee was backing a lift truck down a ramp inside a building while hauling a heavy load. The lift truck brakes failed and the truck went out of control. The lift truck struck and crushed an employee at the bottom of the ramp.



Check the vehicle's brakes during your daily vehicle inspection.

Safe Start-Up Procedures

Entering the Lift Truck

- ▶ Walk around the vehicle to make sure there are no by-standers or maintenance personnel near the vehicle. A maintenance worker could be injured during startup.
- ▶ Make sure the area where you are operating a gasoline or LP-gas powered lift truck is properly ventilated. Carbon monoxide gas can build up in areas that are not ventilated.
- ▶ Step onto the vehicle with both hands on the grab bars. This is called a three-point entry and helps prevent you from slipping and falling.
- ▶ Never use the control levers as handles to pull yourself up. You could be run over or crushed by moving parts if you accidentally activate the lift truck by pulling on the controls.

When to Wear Hearing Protection

OSHA Standard 1910.95 (i) (l) requires hearing protection to be worn when sound levels exceed certain limits (generally, a daily average of 85 or 90 decibels, depending on the circumstances). These levels can be measured with a sound level meter. A hearing conservation program requiring hearing tests and other precautions may also be necessary. Check with the equipment operator's manual, as well as your supervisor, for suggestions on hearing protection as well as instructions on how to wear it properly.



Hearing Protection Rules of Thumb

Hearing protection may be needed if:

- ▶ You have to raise your voice significantly to be heard by someone three feet away.
- ▶ After leaving a noisy area, your ears feel plugged or you hear a mild ringing or whooshing noise that goes away after an hour or two.
- ▶ When you start your car in the morning, the radio is so loud from the evening before that you have to turn it down.

Hazardous Locations

A hazardous location is an environment that contains explosive gases, dust, flammable vapors or other fire and explosion hazards. If you work in a hazardous location, use a lift truck that is designed specifically for hazardous conditions.

Check with your supervisor to make sure the lift truck you are operating is approved for your specific working conditions.

Safe Start-Up

- ▶ Never start the engine from anywhere but the operator's seat or platform.
- ▶ Fasten your safety belt.
- ▶ Make sure the parking brake is set, the forks are fully lowered, the controls are in neutral and the seat and safety belt are adjusted.
- ▶ Start the engine according to the operator's manual.

Accident Report

Employee Crushed When Shorting Starter Terminals

Summary of OSHA Accident Inspection 560391

An employee was working on the engine of a rough-terrain lift truck. He started the engine by shorting the starter terminals and bypassing an interlock switch on the transmission. The truck was still in gear and ran over the employee when the engine started. He was killed.



Never start the engine of a lift truck from anywhere but the operator's seat/platform; never start the engine by shorting across the starter terminals.

- ▶ Before driving, raise the forks high enough to clear obstructions, while still keeping them as low to the ground as possible. A good rule of thumb is four to six inches from the floor. If you are working outside or on rough terrain, you may need to have the forks a little higher.

Parking and Shutdown Procedures

You may find it necessary to leave your vehicle during operation. Protect yourself and others by shutting down the vehicle if you must leave it unattended. Unattended means that you will be 25 feet or more from the vehicle or the vehicle is not in your sight.

How to Park a Lift Truck Safely:

- ▶ Park on a level surface, away from other traffic. Do not block any exits or emergency equipment (such as a fire extinguisher or hydrant).
- ▶ Do not park within 8 feet of the center of railroad tracks.
- ▶ Lower forks to the ground until the forks are resting on the floor or at their lowest position.
- ▶ Put the controls in neutral and set the parking brake.
- ▶ If you must park on an incline, use appropriate chocks to block the wheels.

How to Shut Down a Lift Truck Safely:

If you will be 25 feet or more away from the vehicle, or if the vehicle will be out of your sight, you must follow safe shutdown procedures.

- ▶ Follow safe parking procedures.
- ▶ If equipped with an LP-gas engine, shut off LP-gas valves.
- ▶ Turn the engine off according to your operator's manual.
- ▶ Remove the key.



Be a Safe Driver

Safe lift truck operation starts with a safe driver. While operating a lift truck:

- ▶ Know your company's speed limit. If it is not posted, ask your supervisor.
- ▶ Follow other vehicles at a safe distance. A good rule of thumb is to leave at least three truck lengths between your vehicle and the one in front of you.
- ▶ No stunt driving or horseplay is allowed at any time.
- ▶ Concentrate on driving. Do not smoke, eat or drink while operating a lift truck.

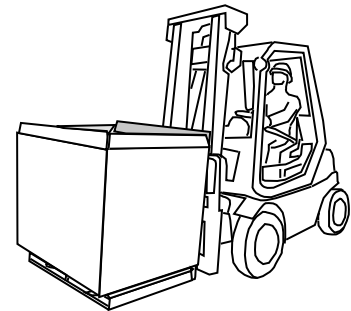

- ▶ Operate safely near coworkers. Never drive a lift truck up to someone.
- ▶ If the vehicle is in need of maintenance or has an "out of service" tag attached to it, do not operate it until it has been fixed.
- ▶ Do not drive over loose objects on the roadway. Always make sure your path is clear.
- ▶ Give the right-of-way to all emergency vehicles.
- ▶ Do not pass other lift trucks stopped at intersections.
- ▶ Do not use the forks to open or close freight doors.
- ▶ When operating on elevators, approach the elevator squarely, after it has come to a complete stop. Follow safe shutdown procedures while on an elevator.

Quiz Yourself

Answers can be found on pages 35-36.

Use the list of words to label the pre-operation inspection points:

Tires

Lift Chains/Rollers/Mast Assembly

Operator's Platform

LP-Gas cylinder

Overhead Guard

Safety Belt

Forks

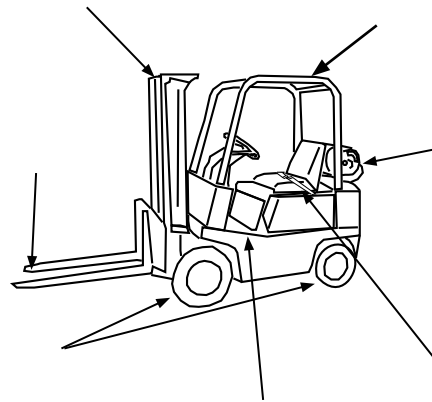

Forks

Operator's Platform

Battery

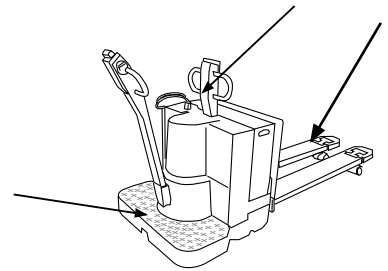

Circle the letter of the correct answer:

1. You should keep at least _____ truck lengths between you and the lift truck in front of you.
A. three
B. one
C. two
2. Make sure the area where you are operating _____ is properly ventilated.
A. an electric pallet truck
B. a gasoline or LP-gas powered truck
C. an electric riding lift truck
3. Always follow safe shutdown procedures when you will be farther than _____ away from the vehicle, or if the truck will be out of your sight.
A. 10 feet
B. 15 feet
C. 25 feet

Avoid Rollover Accidents

Rollovers cause more serious injuries and deaths than any other type of lift truck accident. Rollovers happen when the vehicle becomes unstable. Some of the most common causes for vehicle instability include:

- ▶ turning at high speeds.
- ▶ driving with the load raised.
- ▶ driving or rolling off a loading dock or other raised surface.
- ▶ overloading the forks or lifting off-center loads.
- ▶ driving across a slope.
- ▶ driving on uneven surfaces.

1. Safe Driving Practices

Operating a lift truck is different from operating a car or truck. A lift truck steers from the rear and the controls are not the same as those in a car or truck. Use extra caution when operating a lift truck, especially on uneven surfaces.

Accident Report

Operator Crushed by Overturning Lift Truck

Summary of OSHA Accident Inspection 170063176

An employee was driving a lift truck. The pavement was wet from rainfall and the tires had no tread. When the employee turned the lift truck, it tipped over, throwing him from his seat. He was crushed by the overhead guard. He was not wearing a safety belt, and died from his injuries.



Always wear your safety belt and slow down on wet surfaces.

- ▶ Always drive up or down a slope, not across. Do not turn on a slope.
- ▶ Check your work area for spills, weak flooring, dropoffs, debris, potholes and other hazards.
- ▶ When driving across railroad tracks, cross slowly, at an angle, to keep the vehicle stable.
- ▶ Make sure your tires are properly inflated or that they have the proper ballast.
- ▶ Turn slowly. Use brakes smoothly.
- ▶ Keep the heavy end of a lift truck facing uphill. Typically this means, when the lift truck is loaded, the forks should face uphill. When it is not loaded, the forks should be downhill.
- ▶ Never use unapproved attachments.

Lesson 3

Objectives

1. Evaluate the causes of lift truck rollover accidents.
2. Describe safety procedures to avoid rollover accidents.

The Stability Triangle

Nearly every lift truck is supported by a three point suspension system. The first "point" is located at the center of the rear axle. The other "points" are at either front wheel.

If you draw a line between the three points of a powered industrial truck's suspension system, it would form a triangle. This area is commonly called the stability triangle.

When the truck's center of gravity (CG) is inside the stability triangle, it is stable and will not tip over. When the truck's center of gravity is outside the triangle, it is unstable and will tip over.

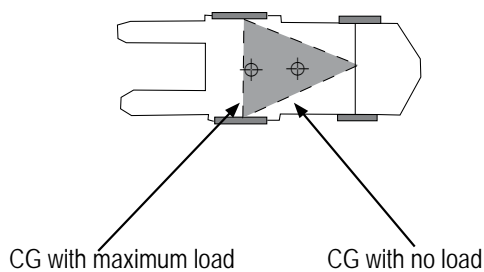

The center of gravity can be shifted out of the stability triangle by:

- ▶ Carrying a load that is heavier than the maximum load capacity.
- ▶ Driving with the load elevated.
- ▶ Driving across an incline
- ▶ Carrying a load off-center.
- ▶ Picking up the load without fully inserting the forks into the pallet.
- ▶ Driving too fast, stopping too quickly.
- ▶ Using an unapproved attachment.
- ▶ Driving on an incline with incorrect load placement. Forks should face downhill when unloaded and uphill when loaded.

2. Lifting and Handling Loads Safely

While transporting a load, make sure it is secure on the forks and that you are driving at a speed which will allow you to stop without causing the load to shift.

Accident Report

Employee Injured When Lift Truck Overturns

Summary of OSHA Accident Inspection 000785469

An employee was moving an empty trash bin with a lift truck. He was driving with the load raised. The truck tipped over, and the employee's leg was crushed between the lift truck's mast and the concrete roadway. His leg was amputated above the knee, and he also suffered a broken arm.



Always carry loads with the forks as low to the ground as possible, while still clearing obstacles.

- ▶ Never drive with the load raised.
- ▶ Carry the load as low to the ground as possible while still leaving clearance for obstacles. A good rule of thumb is 4-6" from the floor on an even surface.
- ▶ Tilt the forks back slightly while transporting a load so it will be less likely to slip off the forks.
- ▶ Raise and lower loads smoothly. Never use jerky or abrupt movements.
- ▶ Do not raise or lower a load while you are driving.
- ▶ Never suspend or free-rig a load.
- ▶ Avoid lifting double-tiered loads.
- ▶ Make sure loads will clear doorways, powerlines and other overhead obstacles.

3. Load Capacity and Stability

Don't exceed your lift truck's maximum capacity, and always load the forks safely. See instructions on the next page for calculating your lift truck's maximum load capacity.

- ▶ Do not overload your lift truck.
- ▶ Check the data plate for the maximum load capacity. Overloading the lift truck will take weight off the back tires, which are responsible for steering the vehicle.
- ▶ Do not use counterweights to increase load capacity.
- ▶ Always carry the load centered on the forks — never to the side.

How to Find the Load Capacity

To know how much your lift truck can handle, check the data plate. There, you will find the rated maximum load (pounds) and the rated load center (inches). The data plate also tells how high that load can be lifted. The rated maximum load is the total weight that the truck can bear with the rated load center. The load center is the distance from the face of the forks to the center of gravity of the load. If the

load center is greater or less than the number listed on the data plate, however, you must use a two-step process to calculate a new actual load capacity.

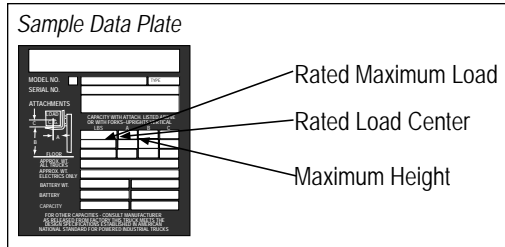

Step 1: Calculate Design Load Capacity

$$(A + B) \times C = \text{Design Load Capacity}$$

A= the distance (inches) from the center of the front wheels to the face of the forks

B= the rated load center (inches, located on data plate)

C= the truck's rated maximum load (pounds, located on data plate) at the rated load center

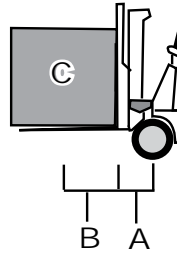

For example, if the rated maximum load is 4,000 lbs, with a rated load center of 24", and it is 18" from the wheel to the face of the forks, the design load capacity is: 168,000 inch pounds.

$$(18 + 24) \times 4,000 = 168,000 \text{ in. lbs.}$$

Once you have calculated the design load capacity, use that amount, along with the actual load center (which can be measured from the edge of the load to the load's center of gravity) to calculate the maximum actual load.

Step 2: Calculate Maximum Load at Actual Load Center

$$\frac{D}{(A + E)} = \text{Maximum Load at Actual Load Center}$$

A= the distance from the center of the front wheels to the face of the forks (same as Step 1)

D= the design load capacity (inch pounds) from Step 1

E= the actual load center (measured from the edge of the load to the load's center of gravity) in inches

For example, with the same truck as above, to find the maximum load with a load center of 36 inches:

$$\frac{168,000}{(18 + 36)} = 3,111 \text{ lbs.}$$

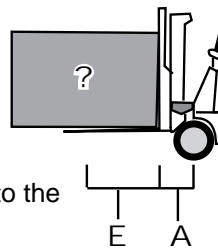

This means with this lift truck, if the load has a 36" load center, the load must not be heavier than 3,111 lbs. Refer to the column (right) for more examples of how to calculate your lift truck's load capacity.

Calculate the Maximum Load

You can use these examples to practice finding the lift truck's maximum load with different load centers.

Lift Truck # 1:

The distance from the center of the front wheels to the face of the forks is 18". The rated load center (LC) is 24" with a rated maximum load of 5,000 lbs. The design load capacity is:

$$(18 + 24) \times 5,000 = 180,000 \text{ in. lbs.}$$

You need to transport something that has an LC of 42". What is the maximum load with this LC?

$$\frac{180,000}{(18 + 42)} = \text{Max. Load at Actual LC}$$

$$\frac{180,000}{(60)} = \text{Max. Load at Actual LC}$$

$$3,000 \text{ lbs.} = \text{Max. Load at 42" LC}$$

The capacity with an actual load center of 42" is 3,000 lbs. Your load with a 42" LC must not be heavier than 3,000 lbs.

Lift Truck # 2:

The distance from the center of the front wheels to the face of the forks is 21". The rated load center is 24" with a rated maximum load of 5,500 lbs. The design load capacity is:

$$(21 + 24) \times 5,500 = 247,500 \text{ in. lbs.}$$

You need to transport something that has a load center of 18". What is the maximum load with this load center?

$$\frac{247,500}{(21 + 18)} = \text{Max. Load at Actual LC}$$

$$\frac{247,500}{(39)} = \text{Max. Load at Actual LC}$$

$$6,346 \text{ lbs.} = \text{Max. Load at 18" LC}$$

The capacity with an actual load center of 18" is 6,346 lbs. Your load with an 18" LC must not be heavier than 6,346 lbs.

Load Placement

Load placement is an important factor to keep your lift truck from tipping over. The load's center of gravity (CG) combines with the lift truck's CG to create the vehicle's overall CG. The height at which you carry a load, the weight of the load and the load's placement determine if the lift truck will be stable.

Which load is positioned correctly?

This load has just been picked from an elevated shelf. Which picture shows the safe load placement?

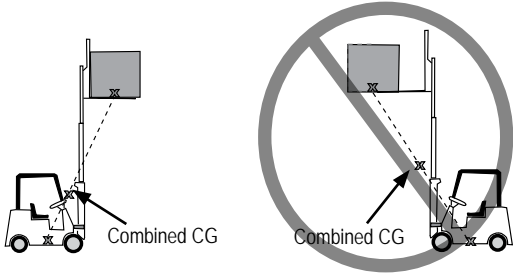

SAFE LOAD

This load is positioned correctly on the forks. It is up against the carriage, and the CG is within the stability triangle. The operator should lower the load before driving.

UNSAFE LOAD

The load is too far forward, pulling the combined CG out of the stability triangle. This vehicle is not stable, and it will tip forward.

Which load is ready for transport?

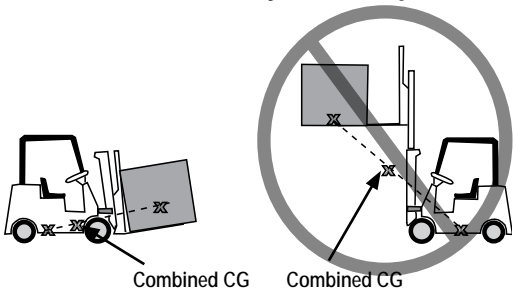

SAFE LOAD

The load is low, but still high enough to clear obstacles, and is tilted back to keep it in place. This is the safest way to transport a load.

UNSAFE LOAD

This lift truck is not ready for transport. The load is too high, and is not positioned correctly on the forks. The operator must lower the load and position it on the forks for safe transport.

Your vehicle will be more stable with a lower center of gravity.



Rollover Safety Procedures

A sit-down rider lift truck is equipped with a rollover protection structure (ROPS) that is designed to protect you when a rollover accident occurs. Do not try to jump free of a sit-down rider lift truck. You can be crushed. Wear your safety belt and stay safe inside the operator's area.

Accident Report

Employee Killed in Lift Truck Rollover

Summary of OSHA Accident Inspection 202043642

An employee was using a lift truck to adjust pallets. The brakes failed and he lost control. The lift truck rolled and he was pinned under the cage and killed.



Keep your safety belt fastened and stay in the seat during a lift truck rollover.

Loading Dock Safety

You can be seriously injured or killed if the trailer you are loading rolls away from the dock. Keep the lift truck away from the edge of ramps and elevated platforms.

Accident Report

Employee Killed While Using Lift Truck to Load Truck

Summary of OSHA Accident Inspection 000822874

An employee was loading a delivery truck on a loading dock. When the employee started to drive onto the delivery truck, it rolled forward because the wheels were not chocked. The lift truck fell backward off of the delivery truck, rolling over the employee. He was crushed.



Always make sure trailer tires are chocked and docking plate is secured before loading a trailer.

- ▶ Speak to the driver of the trailer so he or she knows you are working and does not drive off until you are finished.
- ▶ Talk to the driver to make sure the truck's brakes are set.
- ▶ Walk around the truck to make sure the tires have been chocked and the docking plate is secure.
- ▶ If the trailer is not coupled to a truck, make sure there are fixed jacks to support the weight of the trailer and lift truck.
- ▶ Check the floor of the trailer for cracks or weak spots.
- ▶ Check to make sure the dockboard or bridgeplates are secured, and always drive slowly over them.
- ▶ Make sure the wheel chocks and docking plate have been removed before the driver pulls away.
- ▶ Wheel stops or other positive protection must be used when loading involves railroad cars.

Quiz Yourself

Answers can be found on page 36.

Use the list of words to fill in the blanks:

stable
railroad tracks
elevated

1. Never drive with the load _____.
2. Your vehicle will be more _____ with a lower CG.
3. When driving across _____, drive slowly, at an angle, to keep the vehicle stable.

Circle the picture showing safest load position for driving:

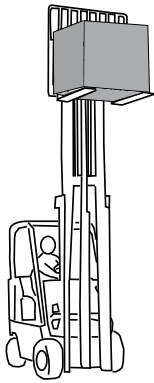

with the load elevated to full extension

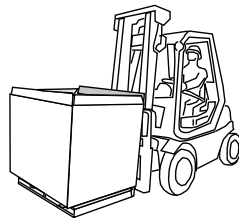

with the load low to the ground, tilted back slightly

Lesson 4

Objectives

1. Recognize hazards that cause runover accidents.
2. Explain safe practices for preventing runover accidents.

Avoid Runover Accidents

1. Watch Out for Pedestrians

- ▶ Do not drive your lift truck in the pedestrian walkways.
- ▶ Stop and sound the horn at intersections, doorways, airlocks and other places where it is hard to see.

Accident Report

Employee Struck By Lift Truck, Leg Later Amputated

Summary of OSHA Accident Inspection 170763007

A lift truck operator was driving in reverse and struck a coworker. A portion of the employee's leg had to be amputated. The operator said he was looking over his shoulder while driving. He did not sound the horn.



Sound the horn before driving in reverse and watch for pedestrians.

- ▶ Limit lift truck use near stairways, exits, breakrooms and restrooms, especially during shift changes and break times.
- ▶ Never allow extra riders on a lift truck. Use only approved passenger devices, and never travel with passengers on the forks.
- ▶ When traveling with a load, make sure you can see in the direction you are traveling. Drive in reverse if the load blocks your view. If you cannot drive in reverse, have a coworker guide you. Make sure your guide person is a safe distance away.
- ▶ Never drive directly toward a worker on foot.
- ▶ Do not pass another lift truck stopped at an intersection; it could be stopped for a worker trying to cross on foot.

Accident Report

Employee Injured When Struck By Lift Truck

Summary of OSHA Accident Inspection 124800038

An employee left her supervisor's office and walked into a lift truck lane. She was struck by a lift truck and broke her wrist. The lift truck driver saw her leaving the office. He tried to brake but was too late. The employee was in a hurry and did not look before stepping into the lift truck lane.



Reduce speed and use care around pedestrian lanes, near offices, doorways and other foot-traffic areas.

2. Safe Parking and Shutdown Procedures

If you must leave the operator's seat while the engine is running, always lower the forks, put the controls in neutral and set the parking brake. If you will be more than 25 feet from the vehicle, or if the vehicle will be out of your sight, follow safe shutdown procedures (see page 13).

Accident Report

Operator Injured by Unattended Lift Truck

Summary of OSHA Accident Inspection 119968725

An employee was carrying a load of pallets on his lift truck. He stopped the lift truck. He thought he set the parking brake. He jumped from the lift truck to adjust the load. He fell and the lift truck rolled over his leg. He had not set the parking brake.



Always set the brake, lower the forks, and put the controls in neutral before leaving the vehicle.

- ▶ Chock the tires if you are parked on a slope to prevent the vehicle from rolling in case of brake failure.
- ▶ Do not to operate the controls if you are outside the operator's platform. You could be crushed by the load or the vehicle's moving parts.
- ▶ Don't jump onto a moving lift truck.

Choose!  **safety**

Driving with Obstructions

Drive in reverse if you must transport a load that obstructs your view. If you cannot drive in reverse, have a coworker guide you. Make sure your coworker is a safe distance away. Discuss what hand signals you will use before you begin.

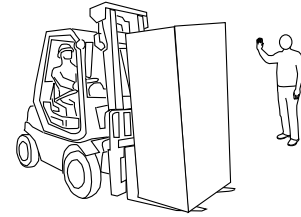

Pedestrian Lanes

Where lift trucks and pedestrians must share work areas, stay out of pedestrian lanes. When approaching a pedestrian, always sound the horn. Do not continue until they respond.

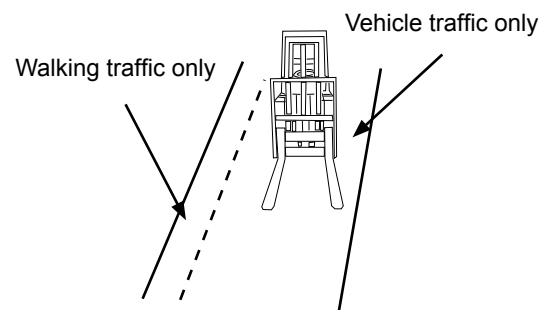

Tail End Swing

A lift truck's rear steering causes the rear or tail end of the vehicle to swing wide when making a turn. When you turn, make sure no bystanders will be hit by the tail end of your lift truck.

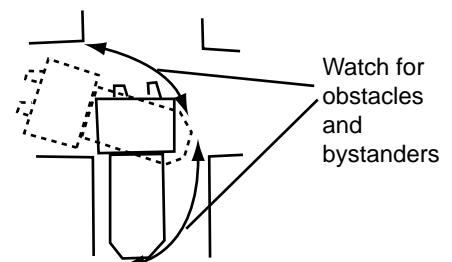

Quiz Yourself

Answers can be found on page 37.

Circle the letter of the correct answer:

1. Chock the _____ if you are parked on an slope to prevent the vehicle from rolling.
A. lift mast
B. tires
C. forks
2. Follow safe shutdown procedures if the lift truck is out of your sight, or if you will be more than _____ away.
A. 10 feet
B. 15 feet
C. 25 feet
3. If a load is blocking your view, _____.
A. keep driving
B. raise the forks so you can see under them
C. drive in reverse and look in the direction you are driving, or have a coworker guide you

Circle the picture showing the safer way to use a spotter:

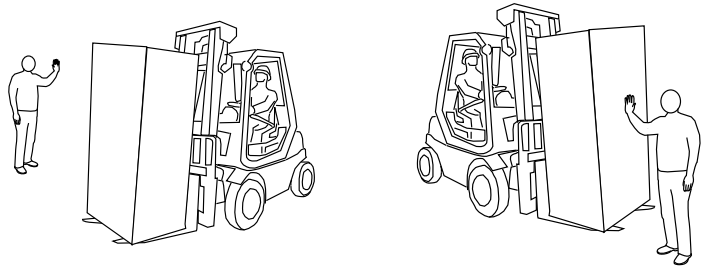

Prevent Crushing Accidents

You can be seriously injured or killed if you get caught in a lift truck's moving parts or under a falling load. Crushing accidents often happen when:

- ▶ An operator's head, hand, foot or other body part is outside the operator's area and is crushed when the lift truck hits an object.
- ▶ The lift truck strikes an object such as a shelf, which enters the cab and crushes the operator.
- ▶ The load falls, crushing the operator or a bystander.
- ▶ An employee is crushed by the lift truck's moving parts.
- ▶ Someone is crushed by a load.

1. Stay in the Operator's Area

Keep your hands, feet, head and all other parts of your body inside the operator's area.

Accident Report
Employee Crushed By Lift Truck's Moving Parts

Summary of NIOSH FACE Investigation 98-MA-049-01
A lift truck operator was placing a load in a narrow aisle. The load became stuck between the shelves. He lowered the forks and backed up the lift truck. He stood between the mast and the cage to see over the load. His foot caught on the mast controls, causing it to tilt toward the cage, crushing him.

 **Stay in the operator's area.**

- ▶ Never dangle your feet outside the vehicle.
- ▶ Never lean outside the operator's area. You could be crushed between the vehicle and an obstacle, such as a shelf, conveyor or a wall.
- ▶ Never put any part of your body between the vehicle and the lift's mast or forks.
- ▶ Do not stand or sit on any part of the lift truck, except in the operator's area.

Lesson 5

Objectives

1. Describe how people can be crushed by lift trucks.
2. Discuss how to prevent crushing accidents.

Pallet Jack Hazards

Operators can be injured when pinned between the pallet jack and a fixed object or when the pallet jack runs up on their heels.

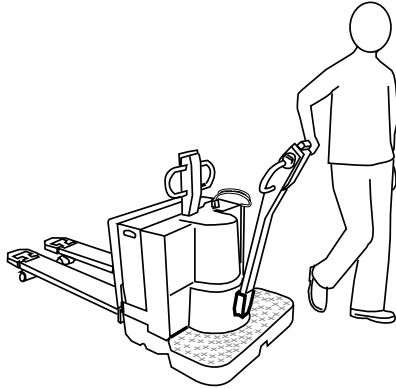

Prevent Injuries:

- ▶ Lead the pallet jack from the side. Face the direction you are traveling, with the forks pointed away from you.
- ▶ Walk behind the pallet jack with the forks pointed ahead of you when you are:
 - ▶ close to a wall or object,
 - ▶ traveling down a slope or
 - ▶ entering an elevator or truck bed.

2. Watch Out for Obstacles

Falling Objects

Accident Report Employees Struck By Falling Fixtures

Summary of OSHA Accident Inspection 122117096

An employee was moving pallets with a lift truck. The pallets struck fluorescent lights that were overhead. The lights fell onto the assembly line where employees were working. Two were hospitalized with shoulder injuries.



Make sure your load does not hit anything above you.

Objects that Enter the Operator's Area

Accident Report Operator Killed When Caught By Chain

Summary of NIOSH FACE Inspection 02NE011

A employee was moving pallets with a stand-up rider lift truck. He backed into a chain that was blocking off a restricted area. He was pinned between the chain and the operator's platform. He could not free himself and died before the chain could be cut away.



Avoid obstacles that could enter the operator's compartment.

- ▶ Watch out for projections, such as railings, shelves, pipes, fixtures, poles, loose lumber, ladders or anything else that could enter the operator's area.
- ▶ Keep all parts of your body within the operator's area.
- ▶ Do not ram the forks against an object or load. The load could fall on you and crush you or a coworker.
- ▶ While operating a stand-up rider lift truck, avoid objects that could enter the rear of the vehicle.
- ▶ Check for obstacles before backing up.

3. Transport Loads Carefully

Hydraulics and lift systems can fail without warning, causing the load to drop. Unsecured loads can shift during transport and fall.

Accident Report

Employee Injured While Moving Barrels With Pallet Truck

Summary of OSHA Accident Inspection 111795019

An employee was using a pallet truck to move a barrel up a small incline. The barrel was not secured to the pallet and it began to fall. The employee tried to push it back, but the barrel was too heavy. He was hospitalized for his injuries.



Always secure loads to pallets — especially odd-shaped loads such as barrels.

- ▶ Never allow anyone under raised loads.
- ▶ When the forks must remain raised during maintenance, use appropriate supports. Never use cinder blocks. Consult your operator's manual.
- ▶ Raise and lower the forks smoothly; avoid abrupt movements.
- ▶ Before picking up or dropping off a load, make sure the load will clear obstacles.
- ▶ Never adjust a lift chain while the forks are raised. Follow safe shutdown procedures and get help from a qualified maintenance person.

Stacking and Transporting Pallets Safely

Make sure your load is stable. All materials should be securely stacked.

- ▶ Do not use broken or damaged pallets.
- ▶ Adjust the width of the forks to match the load (see guide, right).
- ▶ Secure barrels or other liquid containers to keep them from rolling off the forks.
- ▶ When you must transport loose materials, place them in a container.

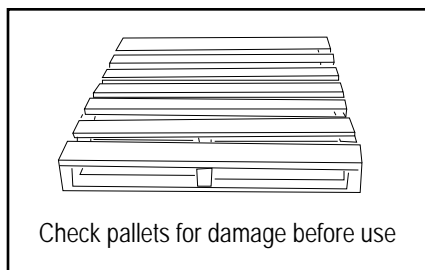

Match Your Forks to Your Load

Adjust the width of the forks to match the load. This means wider loads should have the forks spaced farther apart. Move the forks closer together for narrow loads.

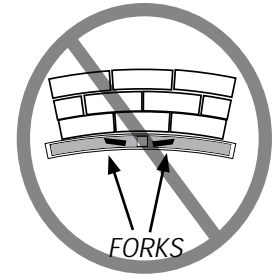
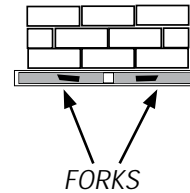

SAFE

The forks are spaced far enough apart to support the load evenly, but not too far apart to cause it to bow inward.

UNSAFE

The forks are too close together, causing the boxes to come apart.

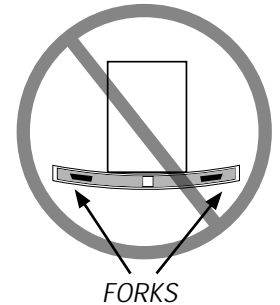
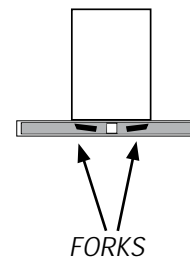

SAFE

The forks are spaced closer together to support the narrow load.

UNSAFE

The forks are too far apart, causing the pallet to bow inward. The narrow load is unstable.

Avoid Crush Points

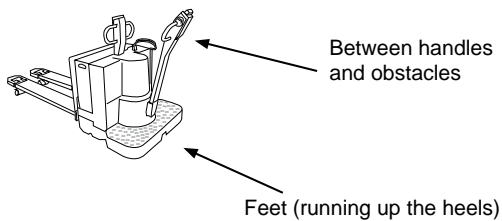
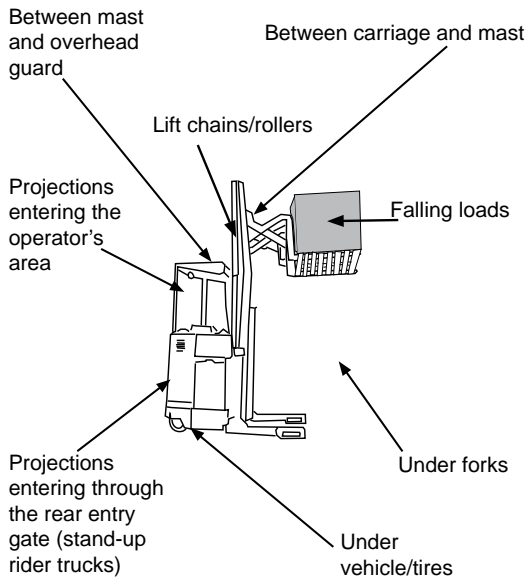

- ▶ Stack materials on the pallet so they will not shift during transport. Some common stacking types include a brick or pinwheel pattern.

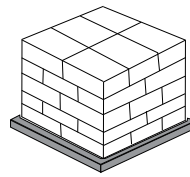

Brick Pattern

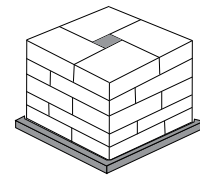

Pinwheel Pattern

- ▶ If you will be stacking items with an irregular shape, such as bags or cylinders, use cardboard, plywood or other material between layers.
- ▶ If you will be stacking materials on racks, check the racks for damage.
- ▶ If the load begins to shift during transport, lower it to the ground and park the vehicle. Re-stack or re-position the load.
- ▶ When setting down a load always check the landing point for signs of overloading such as cracking sounds or bowing. If the area is not secure, pick the load up and place it somewhere else.
- ▶ Do not place heavy loads on top of lighter loads.
- ▶ Do not overload a storage rack.

4. Stay Clear of Moving Parts

Avoid areas where you could be crushed in the vehicle's moving parts. Crush points are created in the equipment's lift chains, rollers, between the mast assembly and carriage and underneath the forks.

Accident Report

Employee Injured When Pinned in Moving Parts

Summary of OSHA Accident Inspection 170153050

An employee was standing on the dash board of a lift truck. His foot hit a lever that moved the mast back. His hips were pinned against the rollover protection structure. He was taken to the hospital.



Stay in the operator's area.

- ▶ Never use the lift mast as a ladder.
- ▶ Do not climb on any part of the forks or lift system.
- ▶ If you experience a problem with the lift system, shut the vehicle down and get help from a qualified maintenance person.

Quiz Yourself

Answers can be found on page 37.

Use the list of words to fill in the blanks:

stand

forks

operator's area

chain

1. Keep your hands, feet, head and all other parts of your body inside the _____.
2. Do not _____ or sit on any part of the lift truck, except the operator's area.
3. Adjust the width of the _____ to match the width of the load.
4. Never adjust a _____ while the lift is elevated. Always follow safe shutdown procedures and get help from a qualified maintenance person.

Lesson 6

Objectives

1. Identify the safest practice for lifting workers.
2. Recall safe maintenance and fueling procedures.
3. Recognize other lift truck hazards.

Preventing Other Injuries and Illnesses

Use Approved Personnel Lifting Devices

An approved personnel lifting device includes guards to protect against moving parts and safety restraints to protect against falls.

- ▶ Lift workers only while the lift truck is stopped and on a level surface.
- ▶ Follow safe parking procedures before allowing workers to enter the lift cage.
- ▶ Never lift workers standing on pallets or forks.

Accident Report

Employee Dies After Falling From Raised Pallet

Summary of NIOSH FACE Inspection 01MI068

An employee was standing on a pallet elevated by a lift truck to a height of six feet. He lost his balance and fell head first to the floor. He died from his injuries.



***Use only approved personnel lift devices.
Make sure workers are properly secured.***

- ▶ Make sure the personnel lift device is secured to the forks. Be certain the lift carriage and forks cannot tilt forward.
- ▶ The operator must stay at the vehicle controls while the person is being raised.
- ▶ The person being lifted must use a personal fall arrest system (such as a lanyard or body harness), standard guard rails or other type of restraint.
- ▶ There must be a guard to protect a raised worker from being crushed by the mast.
- ▶ Raise and lower the platform slowly and smoothly.
- ▶ If the personnel lift device is equipped with controls, ensure that only one set of controls are operable at one time.

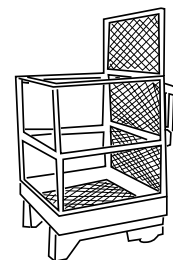

Personnel Lift Device

Maintenance

- ▶ Consult your operator's manual for proper devices to lift and support any part of the lift truck.
- ▶ Park and shut down the lift truck on a level surface, out of the way of traffic. See safe shutdown and parking procedures, page 13.
- ▶ Remove the key and place an “out of service” tag on the controls.

Accident Report

Employee Killed When Lift Truck Slips Off Jack

Summary of OSHA Accident Inspection 300502606

An employee was performing maintenance on a lift truck. The lift truck was supported by a hydraulic jack. The lift truck slipped off the jack and crushed the employee. The parking brake was not set and the wheels were not chocked. The worker did not use jack stands.



Never work under an raised lift truck unless it is properly supported.

- ▶ If you remove guards or covers, replace them when the work is finished.
- ▶ Wait for the radiator to cool before removing the cap. Remove the cap slowly and let pressure escape.
- ▶ Disconnect battery cables before working on the electrical system.
- ▶ Consult your operator's manual for safe jump starting procedures.

Fuel Safety

Follow safe shutdown procedures before refueling. Fueling areas should be well ventilated and away from any sources of sparks or open flames. Consult your operator's manual for specific precautions. General guidelines are:

Gasoline and Diesel Engines

- ▶ Touch the fuel nozzle to the lift truck before opening the fuel cap so a spark will not cause a fire. Keep the nozzle in contact with the filler neck while fueling. Replace the cap as soon as you are finished.
- ▶ Use only approved fuel containers.
- ▶ Never clean your hands or machine parts with gasoline.
- ▶ Clean up spills before starting.

Tire Maintenance Safety

Only qualified personnel should perform tire maintenance. Lift truck tires and wheels are often under high pressure and can explode if not handled carefully. Serious injury or death can occur if a tire explodes.



Explosion Hazard

- ▶ Do not overinflate. Consult your operator's manual for proper inflation.
- ▶ Do not weld on wheels or rims.
- ▶ Punctures must be repaired and ballast checked.
- ▶ If a tire has been run flat or underinflated, remove the wheel and have the rim inspected for damage.
- ▶ Check wheel lug nuts and ensure torques are set to manufacturer's recommendations.
- ▶ Protect yourself by using a tire restraining device such as a tire cage.

Carbon Monoxide Dangers

Make sure the area where you are working is properly ventilated. Gasoline, diesel and LP-gas lift trucks emit Carbon Monoxide (CO), a colorless, odorless, poisonous gas. Signs of CO poisoning include:



Poisonous Gas

- ▶ Shortness of breath
- ▶ Nausea
- ▶ Headache
- ▶ Dizziness
- ▶ Mental confusion
- ▶ Fainting

Even low levels of exposure to CO can have long term effects. If you are working around a fuel-powered lift truck and you experience these symptoms, seek medical attention immediately.

Liquefied Petroleum Gas (LP-gas) Engines

- ▶ Change the LP-gas tanks in a well-ventilated area with the ignition off. Trucks with permanently mounted canisters must be refueled outdoors.
- ▶ If the tank does not have a quick-closing coupling in the fuel line, close the fuel cylinder shutoff valve. Allow the engine to run until it stops. Then remove the tank.
- ▶ Check for leaks in the fittings and hoses before refilling or storing. Apply soapy water and look for bubbles.
- ▶ Only trained personnel should refill LP-gas tanks.
- ▶ LP-gas can settle on clothing and near your body. Do not go near sparks or an open flame after working with LP-gas.
- ▶ No more than two fuel cylinders are allowed on a vehicle.

Accident Report

Employee Burned When LP-gas on Lift Truck Ignites

Summary of OSHA Accident Inspection 127368140

An employee started a lift truck after changing the LP-gas tank. The LP-gas that was in the air ignited and the employee was burned on his face and body. He did not tighten the hose attachment to the LP-gas tank.



Make sure all fittings and hoses are secure after changing LP-gas tanks.

Battery-powered Lift Trucks

- ▶ Only authorized personnel can charge batteries.
- ▶ Charge batteries only in a well ventilated area, with an emergency eye wash station and facilities to neutralize spilled electrolyte (acid). Smoking and open flames are not allowed. Battery gases are explosive.
- ▶ When working with batteries, wear goggles or face shields, rubber aprons, heavy-duty rubber gloves and heavy-duty work boots.
- ▶ Pour acid into water. Do not pour water into acid, excessive heat generation could occur.
- ▶ Keep metal tools and objects away from battery terminals.
- ▶ Concentrated acid can burn flesh in 4-6 seconds.
- ▶ If acid splashes into your eyes, flush with water for at least 15 minutes. If acid contacts skin, wash with soap and water. If acid contacts clothing, remove clothing and immediately wash with soap and water. Seek medical attention as needed.

Work Safely Near Traffic

Lift trucks are not designed for road travel. When you must operate on or near a roadway, follow these guidelines:

- ▶ Use a Slow Moving Vehicle (SMV) emblem to identify the lift truck as a vehicle that travels 25 mph or less.
- ▶ Observe all traffic signals, signs and rules. Give other vehicles the right-of-way.
- ▶ Use caution at intersections. Allow faster-moving vehicles to go first. Make sure you have enough time to get through safely.
- ▶ Do not drive at night unless the lift truck is equipped with lights as required by state law.



High Pressure Hydraulics

Avoid injuries caused by hydraulics:

- ▶ Hydraulic systems can fail without warning.
- ▶ Never stand or work under equipment that has been raised unless it is supported by an approved support device.
- ▶ Check the operator's manual for information on approved support devices.
- ▶ Keep the ends of hoses and connections free of dirt.
- ▶ Never use your hand to check hydraulic hoses for leaks. When you suspect a leak, have a qualified person check for leaks.
- ▶ Check the operator's manual for proper procedures for disconnecting hoses.

Electrical Hazards

Talk with your supervisor before starting a job near an electrical power source.

- ▶ Stay away from power lines, lights, electrical conduits and fixtures.
- ▶ Do not drive over electrical cords.
- ▶ Never drive over downed or exposed power lines.

If the lift truck comes into contact with an electric power source:



1. Remain calm.
2. Follow safe shutdown procedures.
3. Stay in your seat or you could be electrocuted.
4. Get someone to call the power company.
5. Keep people away from the machine.
6. Wait until the power has been disconnected before getting off the vehicle.

Hydraulic injection injuries are serious:

Leaks in hydraulic hoses form a thin, high-pressure stream that quickly slices through skin, causing a serious injury called a hydraulic fluid injection.



Seek medical attention immediately! A hydraulic fluid injection injury is serious, even if it is not painful.

Quiz Yourself

Answers can be found on page 38.

Circle the letter of the correct answer:

1. If you suffer a hydraulic fluid injection injury, you should _____.
A. seek medical attention immediately
B. wait to see a doctor until it starts to look serious
C. don't worry about it because the wound doesn't look too bad
2. Keep _____ in contact with the filler neck while fueling.
A. the keys
B. the nozzle
C. your hand
3. Gasoline may be transported in _____.
A. approved gas containers only
B. a bucket
C. an empty jug
4. The only way to safely lift workers with a lift truck is by _____.
A. having them stand on a pallet
B. having them stand on the forks
C. using an approved personnel lift device

Conclusion

Almost all lift truck accidents are preventable. By practicing safe work habits, you can prevent tragedy on the job. Take control of your own safety by following the practices outlined in this booklet. Use this information to keep your work experience safe.

Choose!  **safety**

Quiz Yourself

Answers can be found on page 39.

Use the list of words to complete the sentences:

slope
load
level
ventilated
safety belt
data plate
alcohol or drugs
stay out

1. Check the vehicle's _____ for load capacity and vehicle weight.
2. Never operate a lift truck under the influence of _____.
3. Always wear your _____ in a sit-down rider lift truck.
4. Never drive across a _____; always drive up or down hill.
5. Park on a _____ surface, away from other traffic, not blocking emergency exits or equipment.
6. Never allow anyone under the _____.
7. Always work in a well _____ area to reduce the risk of CO poisoning.
8. Where lift trucks and pedestrians must share work areas, _____ of pedestrian lanes.

Quiz Yourself Solutions

Lesson 1, Page 7

Use the list of words to fill in the blanks:

1. If the data plate is no longer readable or is missing, get a new one from the manufacturer.
2. Do not operate a lift truck if you are fatigued or under the influence of alcohol or drugs.
3. A rollover is the most commonly reported type of lift truck accident.
4. You must be 18 years of age or older to legally operate a lift truck.

Match the safety image with its meaning:

A. High Pressure Hydraulics

B. Overhead Crushing Hazard

C. Eye Protection Required

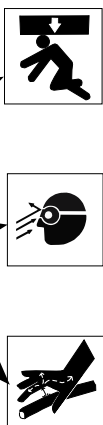

The image shows three safety icons in square boxes. The top icon shows a person being crushed by a falling object, representing an overhead crushing hazard. The middle icon shows a hand being struck by a rotating wheel, representing high pressure hydraulics. The bottom icon shows a hand being struck by a sharp object, representing eye protection required.

Lesson 2, Page 14

Use the list of words to label the pre-operation inspection points:

**lift chains/rollers/
mast assembly**

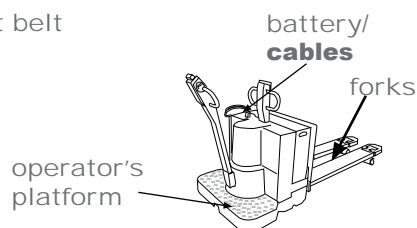
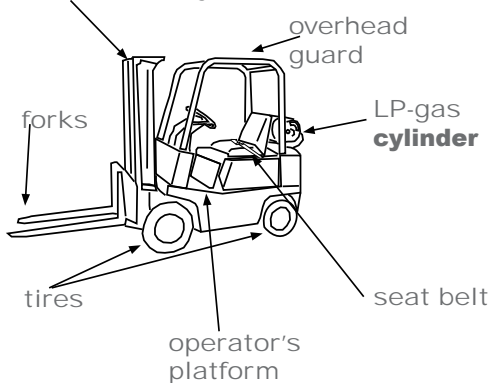

(continued on next page)

Lesson 2, continued

Circle the letter of the correct answer:

1. You should keep at least _____ truck lengths between you and the lift truck in front of you.
 A. three
B. one
C. two
2. Make sure the area where you are operating _____ is properly ventilated.
A. an electric pallet truck
 B. a gasoline or LP-gas powered truck
C. an electric riding lift truck
3. Always follow safe shutdown procedures when you will be farther than _____ away from the vehicle, or if the truck will be out of your sight.
A. 10 feet
B. 15 feet
 C. 25 feet

Lesson 3, Page 19

Use the list of words to fill in the blanks:

1. Never drive with the load elevated.
2. Your vehicle will be more stable with a lower CG.
3. When driving across **railroad tracks**, drive slowly, at an angle, to keep the vehicle stable.

Circle the picture showing the safest load position for driving:

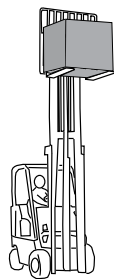

with the load elevated to full extension



with the load low to the ground, tilted back slightly

Lesson 4, page 22

Circle the letter of the correct answer:

1. Chock the _____ if you are parked on a slope to prevent the vehicle from rolling.
A. lift mast
 B. tires
C. forks
2. Follow safe shutdown procedures if the lift truck is out of your sight, or if you will be more than _____ away.
A. 10 feet
B. 15 feet
 C. 25 feet
3. If a load is blocking your view, _____.
A. keep driving
B. raise the forks so you can see under them
 C. drive in reverse and have a coworker guide you

Circle the picture showing the safer way to use a guide:

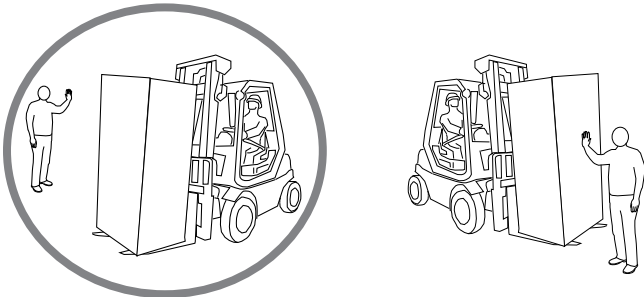

Lesson 5, Page 27

Use the list of words to complete the sentences:

1. Keep all parts of your body inside the operator's area.
2. Do not **stand** _____ or sit on any part of the lift truck, except in the operator's area.
3. Adjust the width of the forks to match the width of the load.
4. Never adjust a **chain** _____ while the lift is elevated. Always follow safe shutdown procedures and get help from a qualified maintenance person.

Lesson 6, Page 32

Circle the letter of the correct answer.

1. If you suffer a hydraulic fluid injection injury, you should _____.
 A. seek medical attention immediately
B. wait to see a doctor until it starts to look serious
C. don't worry about it because the wound doesn't look too bad
2. Keep _____ in contact with the filler neck while fueling.
A. the keys
 B. the nozzle
C. your hand
3. Gasoline may be transported in_____.
 A. only approved gas containers
B. a bucket
C. an empty jug
4. The only way to safely lift personnel with a lift truck is by _____.
A. having them stand on a pallet
B. having them stand on the forks
 C. using an approved personnel lift device

Conclusion, Page 34

Use the list of words to complete the sentences:

1. Check the vehicle's data plate for load capacity and vehicle weight.
2. Never operate a lift truck under the influence of alcohol or drugs.
3. Always wear your safety belt in a sit-down lift truck.
4. Never drive across a slope; always drive up or down hill.
5. Park on a level surface, away from other traffic, not blocking emergency exits or equipment.
6. Never allow anyone under the load.
7. Always work in a well ventilated area to reduce the risk of CO poisoning.
8. Where lift trucks and pedestrians must share work areas, stay out of pedestrian lanes.



**Kansas State University Agricultural Experiment Station
and Cooperative Extension Service**

MF2759

February 2008

K-State Research and Extension is an equal opportunity provider and employer. Issued in furtherance of Cooperative Extension Work, Acts of May 8 and June 30, 1914, as amended. Kansas State University, County Extension Councils, Extension Districts, and United States Department of Agriculture Cooperating, Fred A. Cholick, Director.