

Instructor Guide

**For the Landscaping
and Horticultural Services Industry**



*Knowledge
for Life*

Instructor Guide

Contents

Introduction

What's Inside?	3
Training Techniques	4
Tractor Safety Training Guide.....	10
Motor Vehicle Safety Training Guide	49
Chipper/Shredder Safety Training Guide	88
Skid Steer Safety Training Guide	110
Tree Trimming Safety Training Guide	147
Aerial Lift Safety Training Guide.....	171
Mowing and Trimming Safety Training Guide.....	201

Written by:

Mitch Ricketts, Coordinator, Health, Safety and Environmental Quality, K-State Research and Extension

Sara Lind, Information specialist

Kristy Wieland, Information specialist

Disclaimer

This material was produced under grant number 46G3-HT04 and revised and updated under grant number SH-19503-09-60-F-20 from the Occupational Safety and Health Administration, U.S. Department of Labor. It does not necessarily reflect the views or policies of the U.S. Department of Labor, nor does mention of trade names, commercial products, or organizations imply endorsement by the U.S. government.

This booklet was produced by K-State Research and Extension, Kansas State University, Manhattan, Kansas.

The information in this publication has been compiled from a variety of sources believed to be reliable and to represent the best current opinion on the subject. However, neither K-State Research and Extension nor its authors guarantee accuracy or completeness of any information contained in this publication, and neither K-State Research and Extension or its authors shall be responsible for any errors, omissions, or damages arising out of the use of this information. Additional safety measures may be required under particular circumstances.

What's Inside?

Effective safety training requires careful planning and preparation. This Instructor Guide is designed to improve training techniques to better reach adult learners and a diverse workforce. This manual will guide instructors through safety training courses: tractor, motor vehicle, skid steer, chipper/shredder, tree trimming, aerial lift, and mowing and trimming and assist them in planning and preparing learning activities.

Training Techniques for Adult Learners

Adults learn best when they are active partners in the learning process. Don't lecture to adults. Instead, get them involved in discussions, problem solving and hands-on activities. Give them a chance to share their experiences. Provide lots of encouragement and coaching to help them master the material.

Get their input before you begin planning.

Identify their needs.

Have a purpose and state it clearly.

Apply training to their work.

Involve participants with discussion questions and hands-on exercises.

Give them the chance to provide meaningful feedback.

Use examples, scenarios, problems and visual aids as teaching tools.

Build on the experiences of your participants.

When training adult learners:

Training should be active, not passive.

Adults learn better from doing than from listening. Provide experiences that allow for teamwork, problem solving, and practical application of skills. Participants will lose interest in training if they are not being challenged.

Participants must be able to relate to the training.

Make sure there is a clear connection between training activities and the work experiences of participants. Use realistic examples and problems as teaching tools. Incorporate familiar equipment and visual aids. Ask participants to describe how they can apply training concepts to their own jobs.

Training must address participants' immediate needs.

Concentrate on the most important safety skills participants need for their jobs. Focus on practical information. Keep training activities short and to the point.

Allow participants to have a say in the learning agenda.

Ask participants to help identify important topics for training. Find out what they hope to learn, and take time to discuss safety issues that are important to them.

Encourage participants to share experiences and knowledge during training.

Adults take pride in sharing their knowledge with others. Instead of telling them information, ask them questions and let them tell you what they know. Use the knowledge they already have as a starting point for more advanced learning.

Training in the Diverse Workforce

♥ou must adapt your training techniques to fit the needs of your workforce.

Cultural Differences

Attitudes about safety vary from culture to culture. Make sure participants understand that safety is just as important as production in your organization.

Ask how safety was handled where they worked before:

- ▶ Did they have safety committees?
- ▶ What were the safety rules?
- ▶ Was anyone ever injured?
- ▶ What were the consequences for not following safety rules?

Make sure participants understand any differences in how safety is handled in your organization.

New employees learn by watching. Experienced workers must set an example so new employees understand that safety is expected on the job.

Language Barriers

Participants who do not understand instructions given in English may nod in agreement or say yes even when they do not fully understand what is being said. As a result, they may begin a job without knowing the safest way to perform the work.

Use visual aids and hands-on exercises whenever possible. Demonstrate the tasks and check for comprehension by having participants repeat the tasks correctly.

Be aware that even if the material is in the participant's native language, some workers may not have the reading skills to understand. It can be helpful to partner new employees with more experienced bilingual workers. Mentoring is one of the most effective methods for teaching job skills to low-literacy workers.

- ▶ Always demonstrate the task — don't just talk about it. Ask participants to repeat the same task for you and don't move on until you feel comfortable they understand.
- ▶ Identify training topics simply and clearly.
- ▶ Make it clear when you finish one topic and begin another. For instance, when training about personal protective equipment, hold up a pair of safety glasses and say, "Now we are going to discuss safety glasses." When you move on to hardhats, hold up a hardhat and say, "We have finished talking about safety glasses. Now we are going to discuss hardhats."
- ▶ Break jobs into specific steps and show participants the safe way to perform each step.
- ▶ Use props and visual aids whenever possible.
- ▶ Ask bilingual participants to help plan and assist with training.
- ▶ If a participant is observed working in an unsafe manner, immediately explain and demonstrate how to do the task safely and have the worker repeat the task.

Always make training:

- ✓ Relevant
- ✓ Practical
- ✓ Clear
- ✓ Concise
- ✓ Active

Young Workers

Young workers may not understand dangers that are obvious to older and more experienced workers. They may be less likely to ask questions or bring up problems to persons in positions of authority.

- ▶ Evaluate every job in advance to determine if young workers can perform it safely.
- ▶ Break jobs into specific steps and demonstrate the safe way to perform each step.
- ▶ Ask the worker to repeat the demonstration until you are comfortable that s/he understands.
- ▶ Have young workers complete job-specific safety training before performing any new duties. Training should be repeated periodically and when there are changes in work procedures and equipment.
- ▶ Point out hazards whenever they are encountered.
- ▶ Always model the appropriate behavior — if long-term employees and supervisors take dangerous shortcuts, so will young workers.

Learning Activities

Participants learn best when they have a chance to discover information by applying it to their work. Below are brief explanations of the activities you can use to minimize lecture time and emphasize active participation.

Personal Introductions



Let participants know you are interested in them.

Ask questions:

- ▶ How long have you been working here?
- ▶ Have you witnessed any accidents on the job?
- ▶ What kinds of training have you had in the past?
- ▶ What do you expect to gain from this training?

Keep introduction time brief and informal. Allow enough time for meaningful expression, but keep the introductions moving.

Discussion



Allow participants to relate their experiences, share their knowledge and explore topics of discussion.

Here are a few tips:

- ▶ Don't allow a limited number of participants to dominate the discussion. Draw in hesitant participants by occasionally calling on them by name and asking them if they have anything to add.
- ▶ Don't pressure participants if they appear nervous about speaking up.
- ▶ Don't allow participants to be ridiculed for their opinions. Make sure everyone knows that all points of view are valid topics for discussion.
- ▶ Keep the discussion rolling. Move on to the next topic or activity if discussion is getting bogged down.

Case Studies



Because case studies are realistic examples, participants can apply new information to familiar situations.

Case studies present a problem and allow for discussion, development and evaluation of possible solutions. Discussion of case studies can take any of the following forms:

- ▶ The entire class can work through each case study together.
- ▶ Each individual can work through the case studies and discuss possible solutions with the group.
- ▶ The class can be broken into groups and each group can work on a different case study and report back to the class. This option often provides the best opportunity to encourage teamwork while still allowing all participants to make a meaningful contribution.

Hands-On Exercises



Whenever possible, reinforce every lesson by having participants practice each skill with the same tools and equipment they will be using on the job.

Hands-on exercises often take the following form:

1. Instructor or experienced employee demonstrates the correct technique.
2. Participants practice while instructor observes and coaches.
 - ▶ Make sure the exercise is conducted safely.
 - ▶ Provide any necessary background information.
 - ▶ Provide appropriate supervision.
 - ▶ Take necessary precautions to avoid injury.
 - ▶ Provide frequent, appropriate feedback.

Visual Aids



Help participants understand by illustrating training material with the use of visual aids:

- ▶ If it can be done safely, let participants handle the same tools and equipment they will be using on the job.
- ▶ Use overheads and slides to reinforce training topics.
- ▶ Keep visual aids relevant and make sure they serve to increase understanding.

Questioning



Keep participants actively involved and provide an alternative to lecture by asking, rather than telling them about important concepts. For instance, instead of lecturing participants about how to prevent tractor rollovers on hills, you can involve participants by saying, “What precautions do you take so your tractor doesn’t roll over when you are working on a hill?”

When using questioning as a learning activity:

- ▶ Repeat participant responses or record them on a chalkboard, overhead or flip-chart.
- ▶ Make sure all important information has been discussed and any incorrect responses have been addressed tactfully.

Contests and Competitions



Motivate participants with contest and competitions.

Some examples:

- ▶ Divide the class into groups. In turn, ask each group a multiple choice or true/false question. Each group gets one point for every correct answer. If a group misses a question, allow the next group to answer it for a point. Keep track of points and recognize the winning group. Use the questions as opportunities to discuss training material.
- ▶ Divide the class into groups. Have each group work on a hands-on task (observe safety precautions as noted for hands-on exercises above). Score each group based on a predetermined checklist.

Evaluation



Throughout the training session, use questions and hands-on exercises to evaluate participant progress and knowledge. Provide constructive feedback and ensure participants are mastering important safety concepts and procedures.

Planning and Preparation

Effective safety training requires careful planning and preparation. Address the following before training:

Training Objectives

Develop written statements of the desired knowledge or skill to be demonstrated by participants. Identify the objectives as determined by your organization and/or use those listed in the participant manual. Ask participants to share any important issues they want to address in training.

Facilities

Make sure to provide a safe physical environment, with adequate emergency exits, suitable climate, lighting, restrooms and seating.

Materials

Provide an adequate supply of all training materials. Visual aids and equipment should be available and in good working order.

Recordkeeping

Record attendance. A sample sign-in sheet is provided on page 44 of the Instructor Guide.

Participant Evaluation

Use hands-on performance evaluations and quizzes at the end of each lesson to evaluate participant knowledge.

Evaluation of Training

Ask participants how training can be improved. An example of a training evaluation form is provided on pages 47-48 of the Instructor Guide.

This Instructor Guide provides learning activities for each lesson in the landscaping and horticultural services industry manuals. Review each lesson and select learning activities most appropriate for your audience, materials, facilities and time.

Tractor Safety Training Guide

Suggested Materials

- Tractor Safety* (English, MF2708 and Spanish, MF2708S)
- Sign-in sheet
- Pencils
- Instructor Guide
- Training overheads/slides/projector
- Blank overheads/flipchart/blackboard/pen for listing participant responses and outlining important concepts.
- Tractors and implements for hands-on exercises
- Ear plugs and other protective equipment for hands-on exercises
- Toy tractors and implements for visual aids
- Temporary traffic control devices for hands-on exercises

Sources of Background Information

Tractor and motor vehicle safety manuals available for download:

http://www.ksre.ksu.edu/library/landscaping_equipment_safety.htm

Operator's manuals for tractors (available from dealer)

Length of Time Needed for Training

Review and select the learning activities that are most appropriate. If all of the discussion and hands-on exercises are included in the training it may take up to a full work day. Without the hands-on exercises, the classroom portion will take about two hours.

Welcome and Introduction

- ▶ Introduce yourself.
- ▶ Remind participants of the topic of the training.
- ▶ Discuss exit locations, emergency procedures, breaks, locations of restrooms, ending time and any tests or evaluations.
- ▶ Tell participants you expect them to play an active role by relating their experiences and knowledge.

Participant Introductions

Find out:

- ▶ Who are they?
- ▶ What is their experience with tractors?
- ▶ What do they hope to learn from the training?

Questioning/Discussion

Before beginning Lesson 1:

- ▶ What do participants think are the most common types of accidents that happen with tractors? List ideas on an overhead or flipchart.
- ▶ Have any participants known someone who has been killed or seriously injured in a tractor accident? Would anyone care to share what happened?

Take Control of Your Own Safety

Suggested Objectives

- Define the most commonly reported causes of serious injury and death from tractor accidents.

Discuss Accident Reports on pages 4-5 of *Tractor Safety*.

Discussion Items

- ▶ How well did participants' ideas for the most common cause of accidents match those in the tractor safety manual? (Refer to the overhead or flipchart list made during the introduction.)
- ▶ Which of these hazards represents the greatest risk in your workplace?

Discuss the Safety Signs on page 6 of *Tractor Safety*.

Questioning

Can participants recall any safety signs they have seen on equipment?

Evaluation

As a group, answer the quiz items on page 7 of *Tractor Safety*. Be sure to discuss each item.

Questioning

Before beginning Lesson 2:

- ▶ What safety items do participants check before starting their tractor every day?
- ▶ What are some safety issues participants need to consider when shutting down a tractor?

Lesson 1

Lesson 2

Prepare for Safe Operation

Suggested Objectives

- Identify and locate tractor parts to be checked before operation.
- Discuss steps for safe startup and shutdown.

Discuss the Daily Pre-Operation Checklist and information on pages 8-9 of *Tractor Safety*.

Questioning

What is the company policy for recording pre-operation equipment checks?

Visual Aid

Display the overhead “What’s Wrong with This Picture?” on page 21 of the Instructor Guide. Have participants identify and discuss all safety problems they see. Check participants’ observations from the overhead with the answer key on page 22 of the Instructor Guide.

Discussion

Discuss the company’s safety belt and hearing protection policy. What are some barriers that keep other workers from wear safety belts? Hearing protection? How can these barriers be removed?

Hands-on Exercise

Have participants inspect and wear any personal protective equipment that is required for their work. Discuss the importance of each item.

Try on hearing protection:

- ▶ follow manufacturer’s procedure or use the general procedure below.
- ▶ demonstrate technique.
- ▶ provide feedback as participants practice.

Types of Hearing Protection:

Ear Plugs

- ▶ Clean hands.
- ▶ Roll ear plug between fingers to compress it.
- ▶ Grasp ear from behind your head with opposite hand and pull up to straighten ear canal.
- ▶ Insert ear plug until it blocks sound, then hold in place while it expands. (Count out loud to 20 while it expands.)
- ▶ Ear plug must completely fill ear canal.
- ▶ Test fit by cupping hands over ears and then releasing. There should not be much difference in sound.
- ▶ Wash reusable plugs in warm soapy water after use/throw away disposable after each use.

Hearing Bands

- ▶ Grasp ear from behind your head with opposite hand and pull up to straighten ear canal.
- ▶ Use your hands to press the ear pads into the ear canals.
- ▶ Test fit in a noisy environment: Lightly press band inward and you should not notice much reduction in noise level.



Inserting Ear Plugs

Types of Hearing Protection: cont.

Ear Muffs



- ▶ Make sure the cushions fully cover the ear and seal tightly against the head.
- ▶ Hold the headband at the crown of the head and adjust each cup.
- ▶ Test fit in a noisy environment: Gently push the cups toward your head and release. There should not be much difference in noise level.

Visual Aid

Display the overhead “Is This a Good Idea?” provided on page 23 of the Instructor Guide. Ask participants to identify all safety problems indicated in the story. Then discuss any items in Safe Entry/Startup/Shutdown on page 9-10 of *Tractor Safety* that weren’t mentioned.

Discussion

Discuss what types of accidents can happen when attachments and implements are not hitched properly.

Analysis

Instruct participants to look at the items for Hitching and Unhitching Attachments and Implements on page 10 of *Tractor Safety*. Ask them to write “rollover,” “runover,” “moving parts,” or “multiple hazards” beside each item to indicate what type of accident is most likely to result if the recommendation isn’t observed. Briefly discuss the items as a group.

Discussion Items

- ▶ Discuss why it is important to shut off the tractor and wait 5 minutes for the engine to cool before fueling. (**Note:** For tractors with a fuel inlet near the engine or exhaust.)
- ▶ Why would operators not follow this rule?
- ▶ Why is this rule important?

Questioning

- ▶ What is your company’s policy and practice for tire maintenance?
- ▶ Do any of your tractors have split rim wheels?

Evaluation

Ask participants to answer quiz items on page 11 of *Tractor Safety*. Be sure to discuss each item.

Hands-on Exercise

As a group or individually, inspect a tractor using a checklist such as the Daily Pre-Operation Inspection on page 45 of the Instructor Guide. Safely mount, start, shut down, and dismount a tractor, observing the precautions on pages 9 and 10 of *Tractor Safety*. Hitch and unhitch the various types of equipment that participants will be expected to use.

Lesson 3

Avoiding Rollover Accidents

Suggested Objectives

- Identify safe work procedures to prevent rollover accidents.
- Evaluate safe operating procedures for hills and slopes.

Discuss Accident Reports on pages 12-13 of the Tractor Safety Manual

Visual Aid

Inform participants that rollovers are the most common cause of death on agricultural tractors. Discuss the overhead on page 24 of the Instructor Guide.

Case Studies

Break the class into small groups of three to five people. Provide each group with one of the scenarios on pages 25-28 of this Instructor Guide. Ask each group to discuss their scenario, using the information from Lesson 3 of the Tractor Safety Manual. If there are more than four groups, more than one group can work on the same scenario. Monitor the progress of each group. Bring the class back together and ask for a representative from each group to read their problem and explain their solution. Display case study overheads as each group takes turns. Ask other groups what they think of the proposed solution.

Visual Aid

Display overheads of tractors on slopes provided on pages 29-32 of the Instructor Guide. For each slide, ask the group to identify and explain the proper way to operate a tractor in order to avoid a rollover. Check participant responses with the answer key provided on page 33 of the Instructor Guide.

Visual Aid

Show participants these concepts with a toy tractor on a sloped surface:

- ▶ Demonstrate how rollovers can happen when turning uphill while driving across a slope.

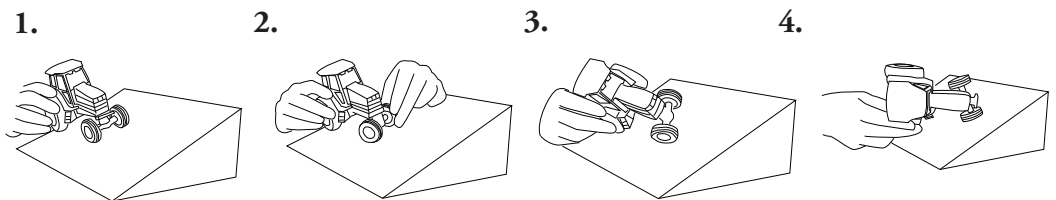

- ▶ Demonstrate how the front end of a tractor will tend to raise if a load is hitched too high.

► Demonstrate how the front end of a tractor may raise up if the tractor tires are prevented from rotating while in forward gear.

1.

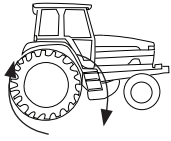

In normal operation, tractor wheels move clockwise in forward gear.

2.

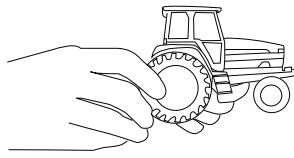

When pulling a fixed object, the tractor wheels can be prevented from turning.

3.

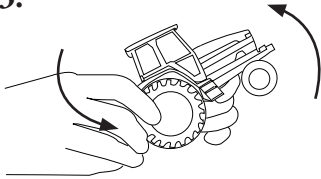

When tractor wheels can't rotate, the tractor front end raises in forward gear.

4.

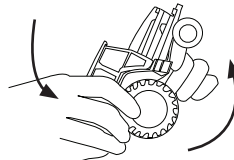

When the front end raises, a rollover can easily occur.

Questioning

Ask participants why it is important to wear a safety belt when operating a tractor that has ROPS.

Discussion

Discuss reasons why other workers may not always wear safety belts. What can be done to increase safety belt use?

Evaluation

Answer the quiz items on page 15 of *Tractor Safety* individually or as a class. Be sure to discuss each item.

Lesson 4

Avoiding Run Over and Collision Accidents

Suggested Objectives

- Discuss types and causes of runover and collision accidents.
- Identify correct operating procedures for avoiding runover and collision accidents.

Discuss Accident Reports on pages 16-17 of *Tractor Safety*.

Case Studies

Break the class into small groups of three to five participants. Provide each group with one of the scenarios from pages 34-37 of the Instructor Guide. Ask each group to answer the question in their scenario, using the information in Lesson 4 of *Tractor Safety*. If there are more than four groups, have more than one group work on the same scenario. Monitor the progress of the groups. Bring the class back together and ask for a representative from each group to read their problem and explain their solution. Ask other groups what they think of the proposed solution.

Evaluation

Answer the quiz questions on page 19 of *Tractor Safety* individually or as a class. Be sure to discuss each item.

Hands-on Exercise

Take the class outdoors and point out several distinct areas nearby. (e.g., ditches, fields, wooded areas, embankments, etc.). Break the class into groups of three to five participants. Ask each group to evaluate one of the areas and report back to the class regarding whether it is safe to operate a tractor in that particular area and list any precautions that are necessary in order to prevent a rollover, runover or collision accident.

Moving Parts and Machinery Hazards

Lesson 5

Suggested Objectives

- Identify mechanical tractor and implement hazards.
- Describe how to avoid injury from moving machine parts.

Discuss the Accident Report on page 20 of *Tractor Safety*.

Discussion

Ask participants to give specific examples of how people get caught in the moving parts of tractors and implements. List participant responses on an overhead or flip-chart.

Questioning

If your clothing or hair gets caught in a PTO shaft, how long do you have to react before your body gets completely pulled in?

Discuss the PTO information in the box on page 21 of *Tractor Safety*.

Discussion

Have any participants known someone who has been killed or seriously injured in a accident involving a PTO shaft? Would anyone care to share what happened?

Analysis

Have participants read the Other Mechanical Hazards on pages 21-22 of *Tractor Safety*. Ask each participant to write an example in the margin next to any hazards they have seen on their own equipment. When finished, ask different participants to briefly describe one of the examples they recorded.

Discussion Items

- ▶ A tractor or implement comes in contact with a power line. What should be done?

Discuss the electrical information in the box on page 22 of *Tractor Safety*.

- ▶ Is it okay to move a power line out of the way with a two-by-four in order to drive a tractor with a tall load under the line?
- ▶ A power line is in the way of your work. Discuss procedures for contacting the power company to shut off power.
- ▶ Discuss the company's policies and practices regarding checking and repairing hydraulic fluid leaks.

Hands-on Exercise

Have several tractors available with attached equipment. Break the class into groups of three to five participants. Ask each group to evaluate one of the tractor-attachments and report back to the class regarding whether guards are in place and operating properly and any precautions that are necessary in order to prevent contact with hazardous parts.

Evaluation

Answer the quiz items on page 23 of *Tractor Safety*, either individually or as a class. Be sure to discuss each item.

Highway Safety and Other Hazards

Suggested Objectives

- Identify safe operating procedures when driving a tractor on the highway.
- Explain other health and safety risks associated with operating a tractor.

Contest

Divide the class into groups. Display the contest items provided on pages 38-42 of the Instructor Guide. In turn, ask each group a multiple choice or true/false question from the overheads. Each group gets one point for every correct answer. If a group misses a question, allow the next group to answer it for a point. Keep track of points and recognize the winning group. Use the questions as opportunities to discuss the training material. Answer key provided on page 43 of the Instructor Guide.

Evaluation

Answer the quiz items on page 31 of *Tractor Safety*, either individually or as a class. Be sure to discuss each item.

Hands-on Exercise

In a safe area such as a private road or parking lot on the organization's property, have participants set up a roadside work area using traffic cones and flaggers, as appropriate. Make sure all participants wear brightly-colored reflective vests and any other safety equipment that the organization requires for this type of work. Guidelines for roadside work areas are detailed in *Motor Vehicle Safety for the Landscape and Horticultural Services Industry* (MF2709) at:

http://www.ksre.ksu.edu/library/landscaping_equipment_safety.htm

Lesson 6

Conclusion

Review

Ask each participant to discuss at least one task they are going to perform differently as a result of the tractor safety training.

Discussion

Ask participants to share any questions or concerns they may still have or want to discuss further.

Evaluation

Answer the quiz questions on page 33 of *Tractor Safety* individually or as a group. Be sure to discuss each item.

Hands-on Performance Evaluation

In a safe area with adequate supervision, have each participant complete a hands-on performance evaluation while operating a tractor (including attachments, if appropriate). The evaluation may include:

- ✓ Pre-Operation Inspection provided on page 45 of the Instructor Guide
- ✓ Attaching implements
- ✓ Safe start-up
- ✓ Driving the tractor to perform a safe task
- ✓ Removal of implements
- ✓ Safe shut-down

A scoresheet for the performance evaluation is provided on page 46 of the Instructor Guide.

What's Wrong With This Picture?

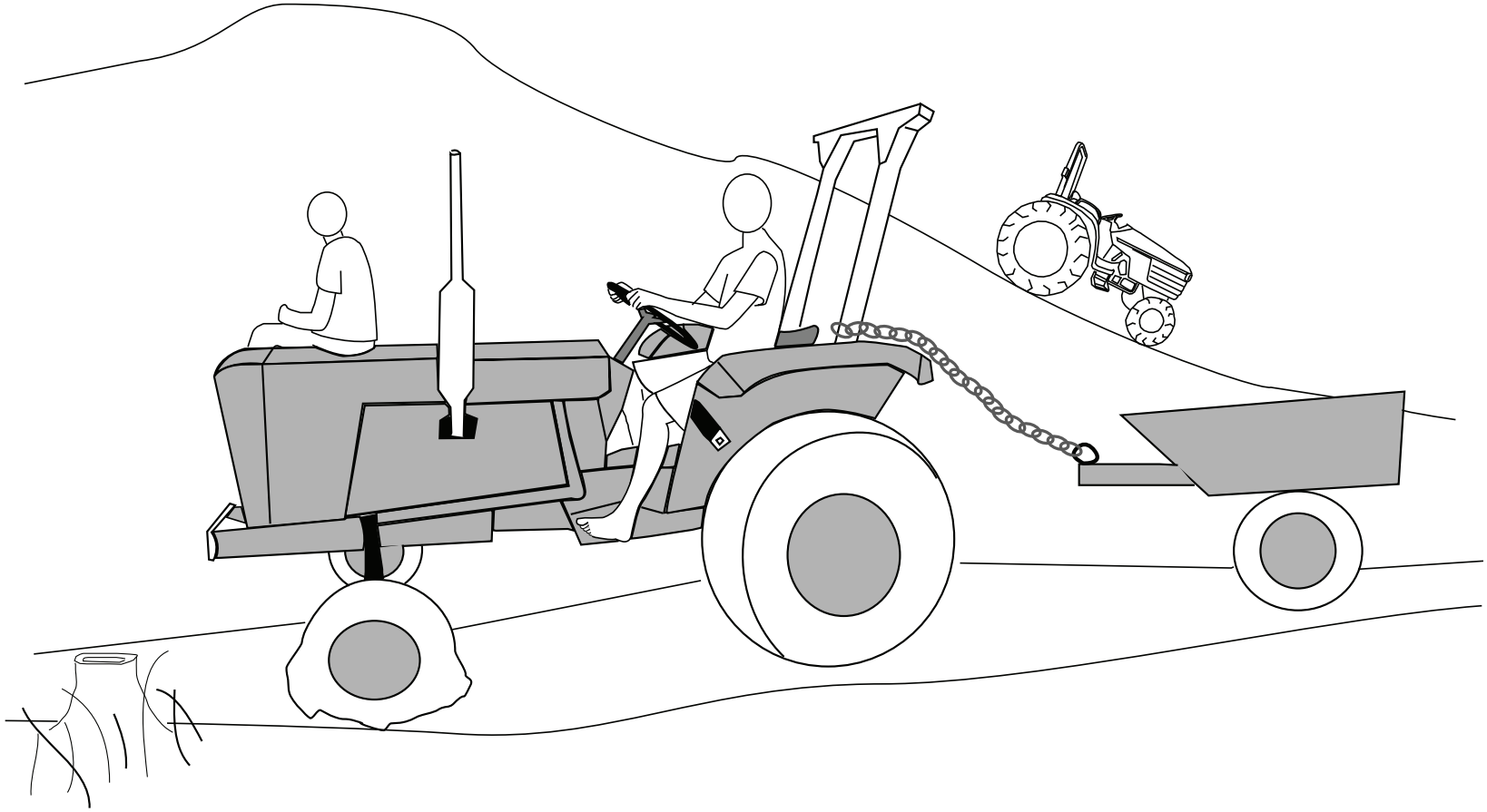

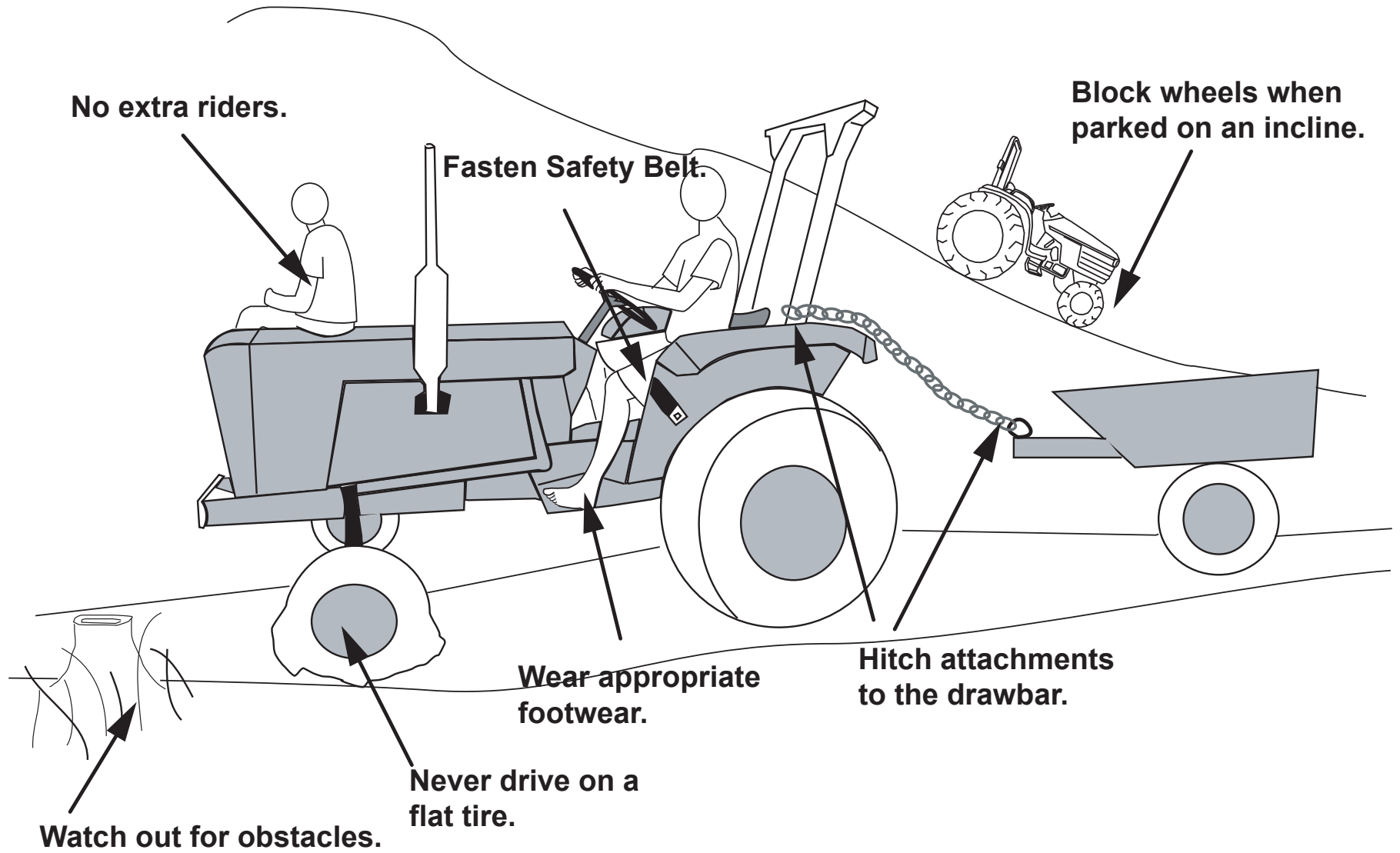

Is This a Good Idea?

A worker was using a tractor with a trailing mower. He saw some rope on the ground and didn't want it to get caught in the mower. With the engine and PTO running, he put the tractor in neutral and climbed down, stepping on the ground in front of the right rear tractor tire (the parking brake wasn't working). After picking up the rope, he walked around the back of the tractor, stepped over the spinning PTO shaft, and climbed into the seat, using the PTO master shield as a step.

Tractor Rollovers

85% are SIDE rollovers

15% are REAR rollovers

**Less than 1% are
FRONT rollovers**

SOURCE: National Institute for Occupational Safety and Health.

Trac-Safe: A Community-Based Program for Reducing Injuries and Deaths Due to Tractor Overturms. Cincinnati, Ohio: 1996.

#1 You will be using a tractor to haul a heavy implement from one job site to another. Part of the route is a gravel country road. The other part is a highway. There are some hills along the roads. What safety issues should you consider before starting in order to reduce the chances of a rollover accident?

#2 You have to mow a ditch along a roadside with a tractor and trailing mower. What issues should you consider, and what precautions should you take in order to reduce the risk of a rollover accident?

#3 You need to pull out some old stumps with a tractor. What issues should you consider and what precautions should you take in order to reduce the risk of a rollover accident?

#4 You will be using a tractor with a front-end attachment to load dirt onto a truck. You have no choice but to park the truck downhill of the dirt pile. What issues should you consider and what precautions should you take in order to reduce the risk of a rollover accident?

Which is Safer?

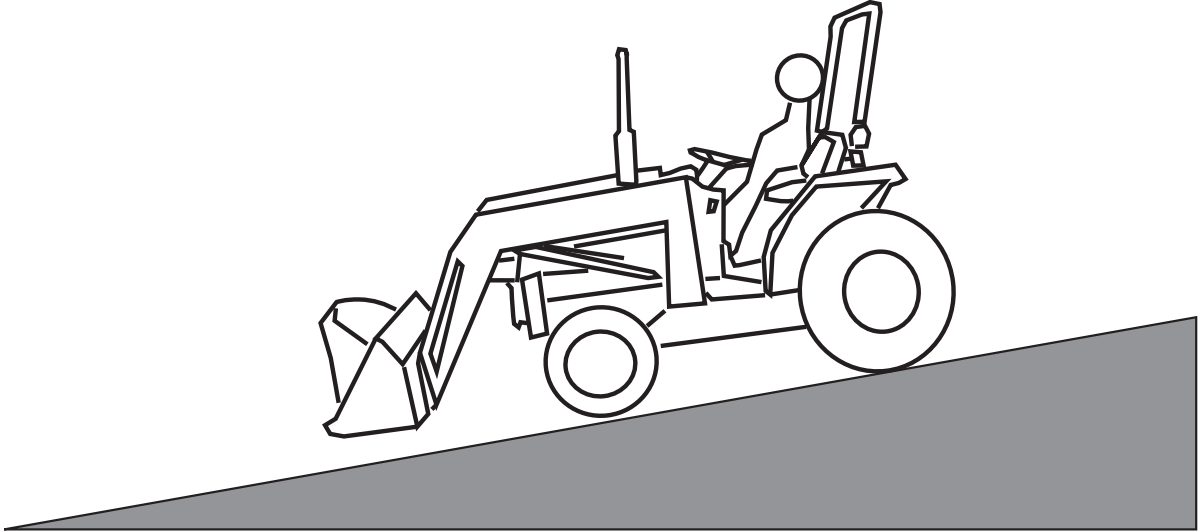
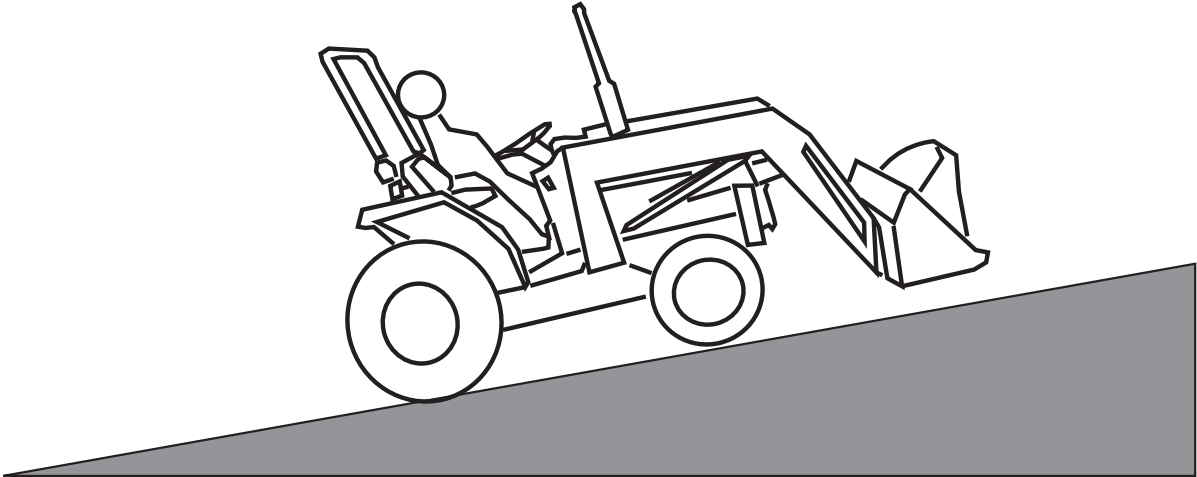

Which is Safer?

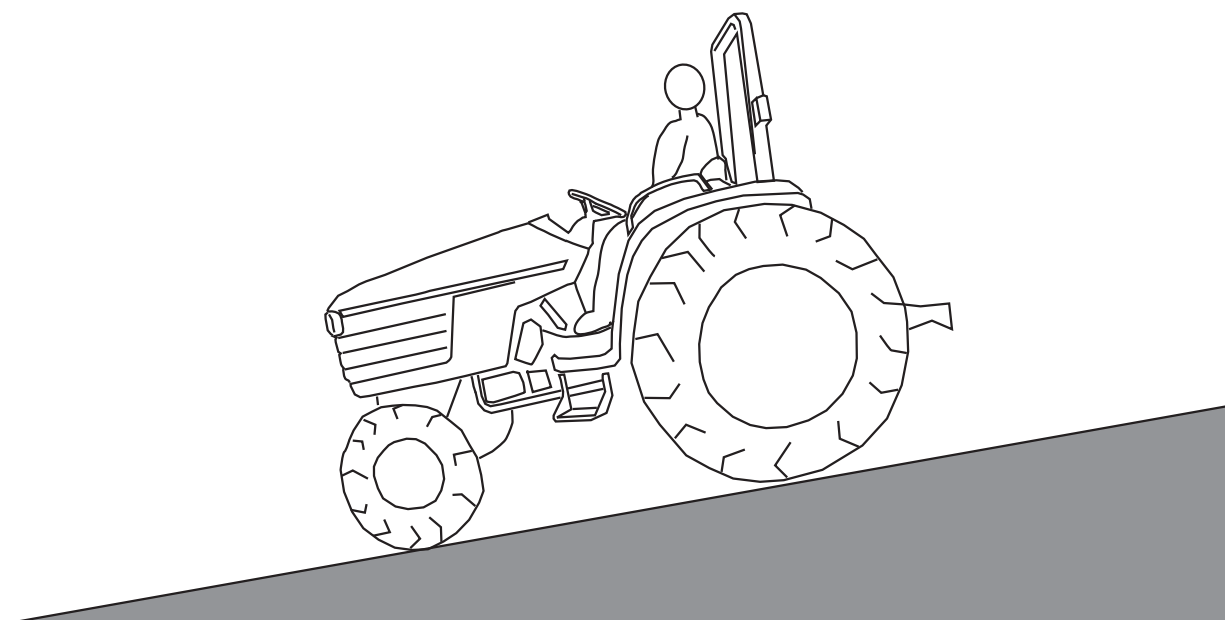
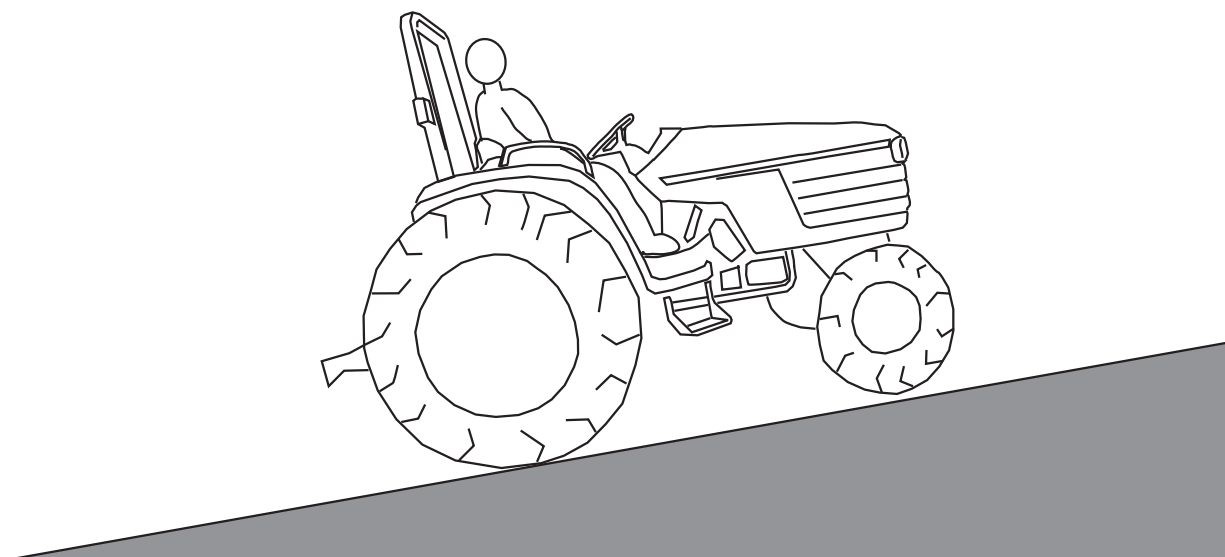

Which is Safer?

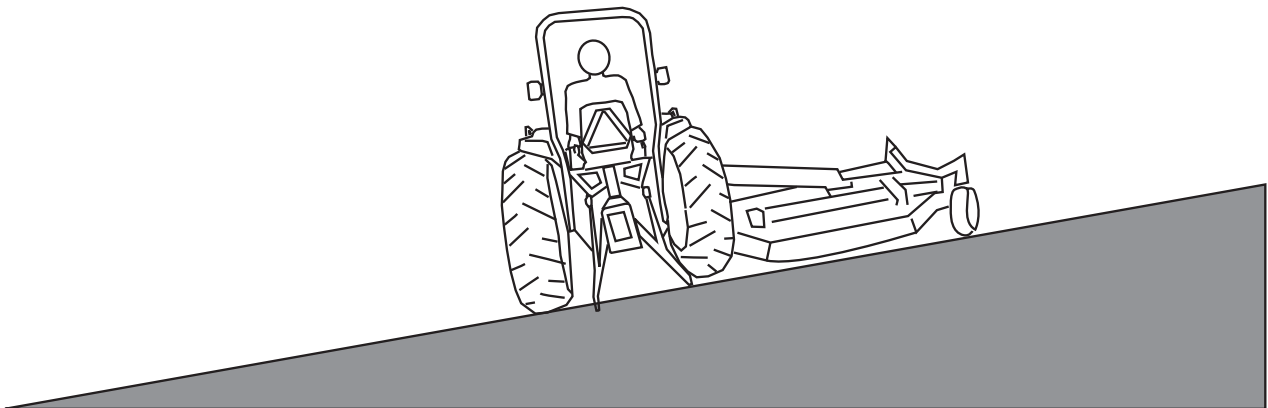
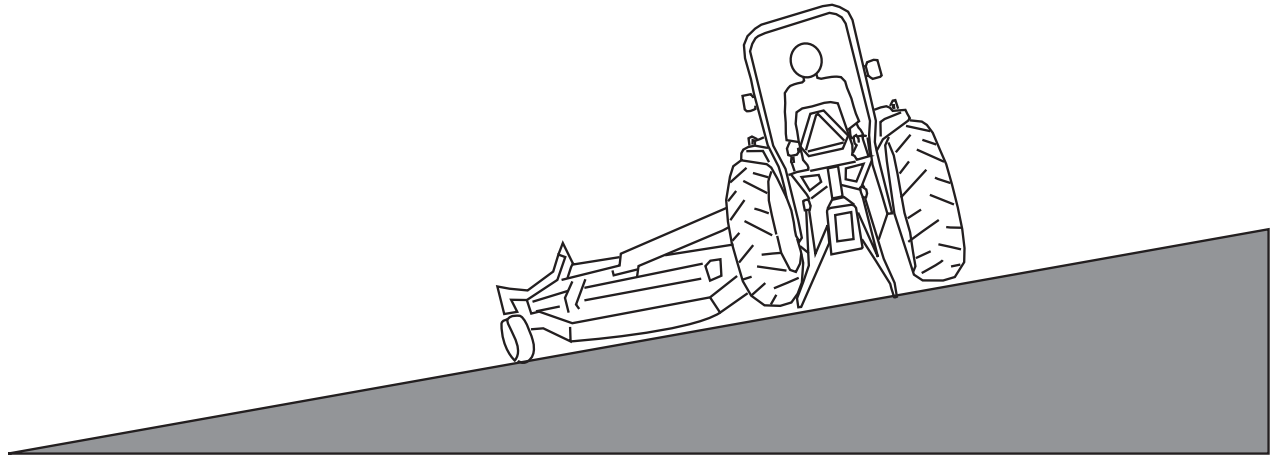

Which is Safer?

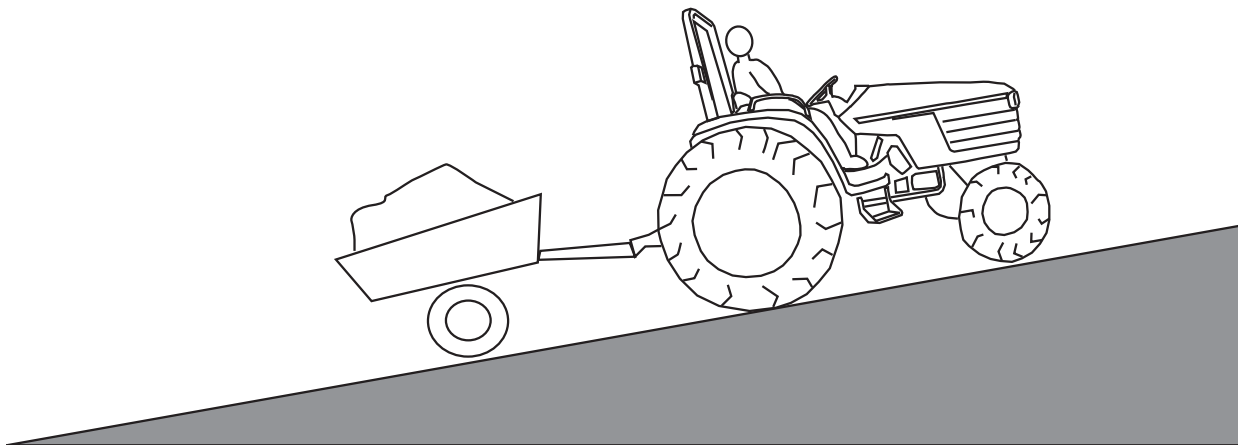
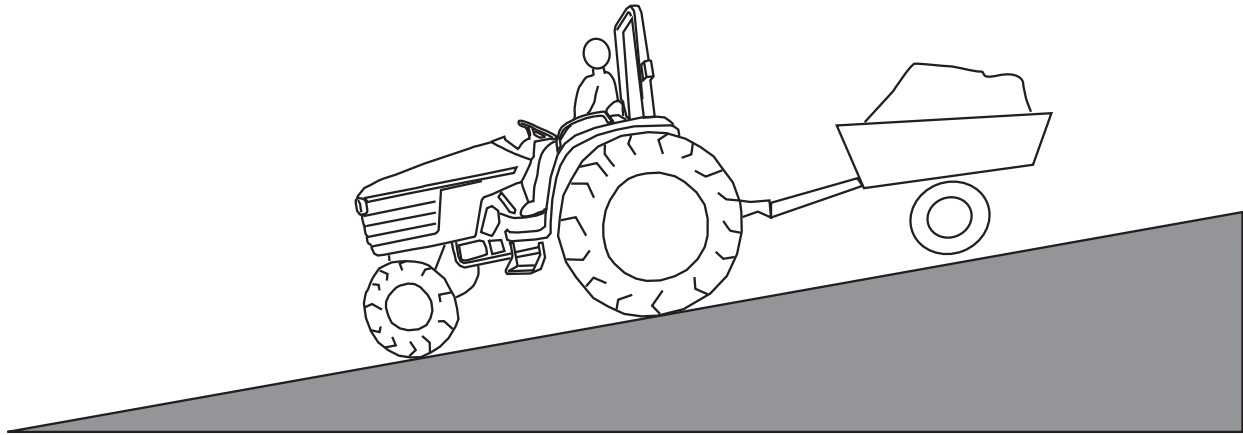

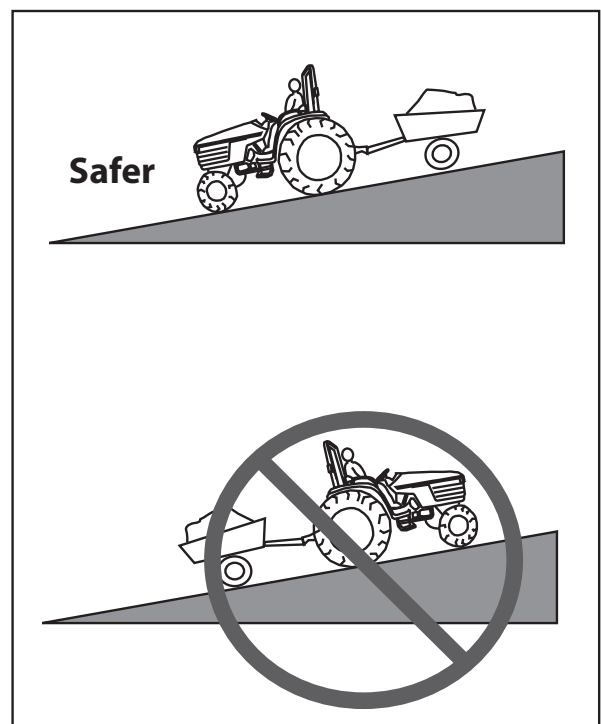
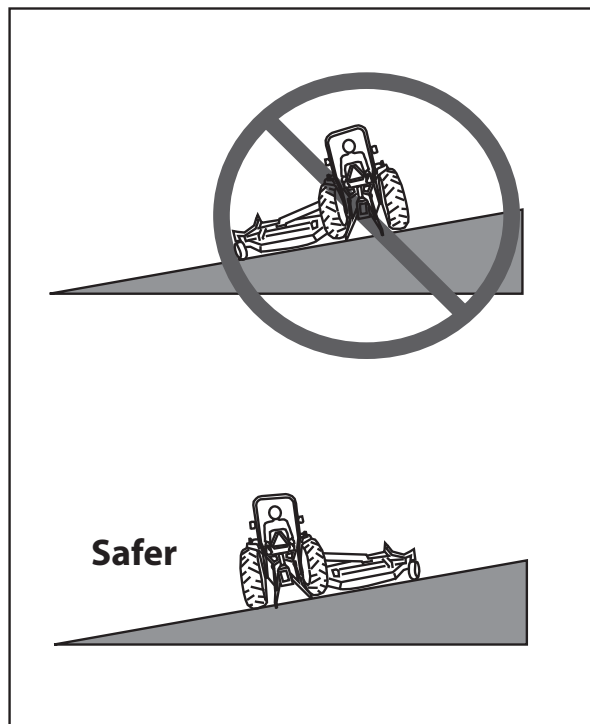
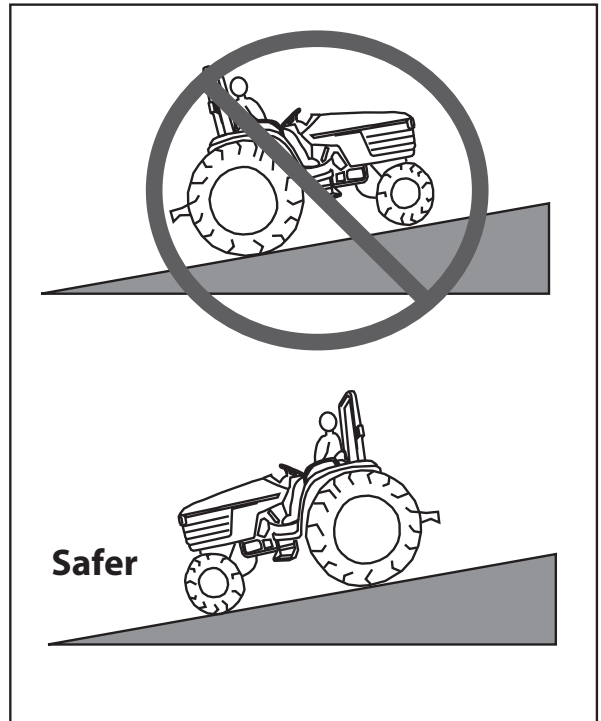
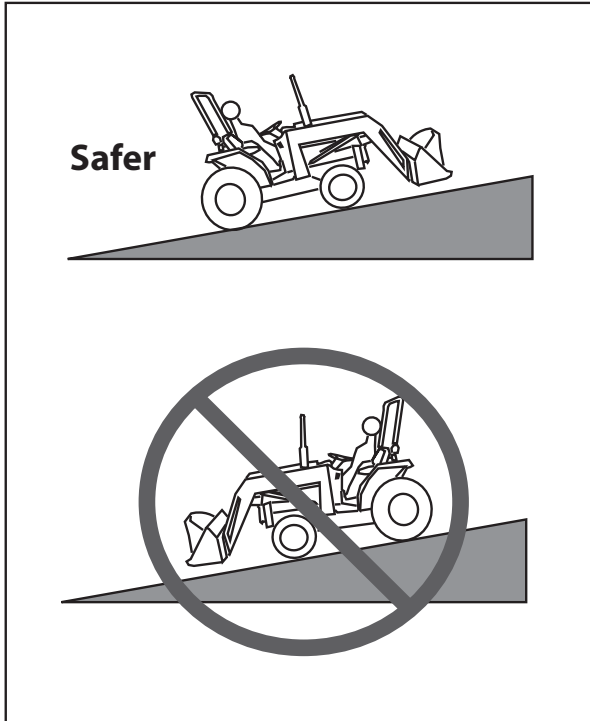

#1 Describe how a tractor operator could get hurt in a runover or collision while operating a tractor with a trailing implement in an area with lots of trees, brush, and low-hanging branches. What are the most important issues you should consider to prevent this from happening?

#2 Describe how a worker on foot could be run over while a tractor with a trailing mower is being operated in a landscaping project involving many workers. What are the most important issues you should consider to prevent this from happening?

#3 Describe how an operator or a helper could get hurt while hitching an implement to a tractor. What are the most important issues you should consider to prevent this from happening?

#4 Describe how an operator or a helper could get hurt when trying to start a tractor that has a battery or starter problems. What are the most important issues you should consider to prevent this from happening?

1. Light headedness, dizziness and clammy, moist skin are most likely to be signs of:

- a. heat stroke.**
- b. heat exhaustion.**
- c. heat rash.**

2. Prolonged exposure to sunlight causes:

- a. skin cancer.**
- b. cataracts.**
- c. both A & B.**

3. A slow-moving vehicle (SMV) sign is required when driving a tractor or other vehicle on a public road at speeds of:

- a. 25 MPH or less.**
- b. 30 MPH or less.**
- c. 35 MPH or less.**

- 4. Use _____ to stop bleeding from minor cuts:**
- a. a tourniquet**
 - b. direct pressure**
 - c. neither A nor B**
- 5. Disorientation, confusion, and hot, dry, red skin are likely to indicate:**
- a. heat stroke.**
 - b. heat exhaustion.**
 - c. neither A nor B.**
- 6. Prevent skin cancer by covering exposed skin with a broad spectrum sunscreen that has a Sun Protection Factor (SPF) of at least:**
- a. 5.**
 - b. 10.**
 - c. 15.**

7. When working in the heat, how much water should you drink to avoid heat illness?

- a. 1 cup per hour**
- b. 1 quart per hour**
- c. 1 gallon per hour**

8. Treat a minor burn by:

- a. cooling the burn with cool water.**
- b. warming the burn with warm water.**
- c. breaking any blisters.**

9. When operating on a public road, you should use a safety chain strong enough to hold the towed implement if the primary hitch fails.

True/False

10. The metal cab of an enclosed tractor provides no protection against lightning.

True/False

11. When you can see lightning and hear thunder, lightning is close enough to strike you.

True/False

12. You may die of carbon monoxide poisoning if you run a tractor engine indoors with no ventilation.

True/False

13. If you are bitten by a poisonous snake, use a knife to cut an X on each fang mark, and suck out the poison.

True/False

14. If the tractor is equipped with left and right brake pedals, hitting one brake in road gear may cause the tractor to turn suddenly.

True/False

1. b

9. T

2. c

10. F

3. a

11. T

4. b

12. T

5. a

13. F

6. c

14. T

7. b

8. a

Daily Pre-Operation Inspection: Tractor

Operator _____ Date _____

Tractor ID _____ Make/Model _____

Location: _____

Item	OK	Needs Attention	Comments
Safety Belt			
ROPS			
Guards/Shields			
Tires			
Steps/Platform			
Fluids Leaks			
Fluids Levels			
● Oil			
● Coolant			
● Fuel			
● Other			

Operator Performance Evaluation: Tractor

Operator: _____ Date: _____

Tractor ID: _____ Make/Model: _____

Instructor: _____ Location: _____

	Satisfactory	Needs Improvement
Follows Pre-Operation Inspection		
Safe Start Up		
● Clear the area of bystanders		
● Wear hearing protection, as necessary		
● Dress appropriately		
● Use the three point technique for entering		
● Check that the parking brake is engaged and tractor is in neutral		
● Fasten safety belt and adjust controls		
● Start the tractor according to manufacturer instructions		
Safe Hitching/Unhitching of Attachments/Implements		
● Hitch towed loads to drawbar only		
● Hitch/Unhitch on level ground only		
● Make sure all safety guards are in place and undamaged		
● Keep bystanders out of the area between the tractor and equipment		
● Hitch equipment according to manufacturer's instructions		
Demonstrate Driving Skills		
● Operate at safe speed		
● Operate safely on hills		
● Start and stop smoothly		
● Avoid obstacles and hazardous areas		
● Follow safe backing procedures		
Safe Shut Down		
● Park on level surface		
● Lower all attachments to the ground		
● Move controls to neutral, lock controls, and set parking brake		
● Disengage or turn off PTO		
● Wait for moving parts to stop before dismounting		
● Block wheels if ground is not level		

Training Evaluation Form

Training Topic: _____

Date: _____ Trainer: _____

Location: _____

Instructions: Please use this form to help us improve the safety training. For each of the following items, circle the letter next to the answer that best describes your opinion. You may write in additional comments if you wish. Do not put your name on this form.

- 1. Was the training easy to understand?
 - a. Yes. I understood everything we talked about.
 - b. Mostly. I understood most of the things we talked about.
 - c. No. I did not understand the training.

Use this space to list anything that was hard to understand. If possible, let us know if there is anything we can do to make it easier to understand. _____

- 2. Did the training address the most important dangers related to the training topic?
 - a. Yes. It definitely included all of the most important dangers.
 - b. Mostly. It included nearly all of the most important dangers.
 - c. No. It left out many important issues.

Use this space to list any important dangers that should be added to the training. _____

- 3. Did the training describe all of the most important safety practices that workers should observe related to the training topic?
 - a. Yes. It definitely included all of the most important safety practices.
 - b. Mostly. It included nearly all of the most important safety practices.
 - c. No. It left out many important safety practices.

Use this space to list any important safety practices that should be added to the training. _____

- 4. Did you learn some important things today that you didn't know before?
 - a. Yes. I learned a lot of important new information.
 - b. Mostly. I learned some important new things
 - c. No. The information wasn't very important.
 - d. The information was important, but I already knew most of it.

Use this space to list anything you think we should add to the training. _____

- 5. Will you use the information you learned in today’s training to work more safely in the future?
 - a. Yes. I will definitely use the information to work more safely in the future.
 - b. Maybe. I might use the information to work more safely in the future.
 - c. No. I will not follow the safe work practices that we talked about in the training.
 - d. I am already following all of the safe work practices we talked about, and I will continue to do so in the future.

Use this space to list any reasons why you might not follow the safe work practices that we talked about.

- 6. Was the training worthwhile?
 - a. Yes. It was definitely worth my time.
 - b. Mostly. It was somewhat helpful.
 - c. No. It was a waste of my time.

Use this space to list any reasons why you might not follow the safe work practices that we talked about.

- 7. Would you recommend the training to other landscaping and horticultural services workers?
 - a. Yes. It would definitely be helpful to others.
 - b. Probably. It would probably be helpful to others.
 - c. No. It would not be helpful to others.

- 8. Use this space for any other comments you have about the training: _____

Motor Vehicle Safety Training Guide

Suggested Materials

- Motor Vehicle Safety* (English, 2709; Spanish, 2709S)
- Sign-in sheet
- Pencils
- Instructor Guide
- Training overheads/slides/projector
- Blank overheads/flipchart/blackboard/pen for listing participant responses and outlining important concepts
- Slow Moving Vehicle sign for visual aid
- Model vehicle and trailer blocks/board for demonstrating blocking trailer for unloading and loading on a slope
- Temporary traffic control devices, reflective vests and other equipment for hands-on exercises and visual aids
- Vehicle, trailer, and blocks for hands-on exercise

Sources of Background Information

Motor Vehicle Safety available for download:

http://www.ksre.ksu.edu/library/landscaping_equipment_safety.htm

Operator's manuals for motor vehicles (available from dealer)

Manual on Uniform Traffic Control Devices (MUTCD) available for download:

<http://mutcd.fhwa.dot.gov/>

Length of Time Needed for Training

Review and select the learning activities that are most appropriate. If all of the discussion and hands-on exercises are included in the training it may take up to a full work day. Without the hands-on exercises, the classroom portion will take about two hours.

Welcome and Introduction

- ▶ Introduce yourself.
- ▶ Remind participants of the topic of the training.
- ▶ Discuss exit locations, emergency procedures, breaks, locations of restrooms, ending time and any tests or evaluations.
- ▶ Tell participants you expect them to play an active role by relating their experiences and knowledge.

Participant Introductions

Find out:

- ▶ Who are they?
- ▶ What is their experience with motor vehicles in the workplace?
- ▶ What do they hope to learn from the training?

Questioning/Discussion

Before beginning Lesson 1:

- ▶ Ask participants what types of motor vehicle incidents are most likely to seriously injure or kill them at their workplace. List ideas on an overhead or flipchart.

Lesson 1

Take Charge of Your Own Safety

Suggested Objectives

- Identify the leading cause of accidental death on the job.
- Identify safe work habits for operating motor vehicles.

Discuss Accident Reports on pages 4-5 of *Motor Vehicle Safety*.

Discussion Items

- ▶ Have any participants known someone who has been killed or seriously injured in a motor vehicle accident while on the job? Would any participant care to share what happened?
- ▶ How well did participants' ideas for the most common cause of accidents match those in the Motor Vehicle Safety Manual? (Refer to the overhead or flipchart list made during the introduction.)

Evaluation

As a group, answer the quiz items on page 6 of *Motor Vehicle Safety*. Be sure to discuss each item.

Questioning/Discussion

Before beginning Lesson 2:

- ▶ What steps do participants take to protect themselves, coworkers, motorists and equipment when working near traffic? List ideas on overhead or flipchart.

Working Safely Near Traffic

Lesson 2

Suggested Objectives

- Identify safety procedures to use when working on or near the shoulder of the roadway.
- Recall how to use traffic control devices in your work zone.

Discuss the Accident Report on page 7 of *Motor Vehicle Safety*.

Visual Aid

- ▶ Display temporary traffic control devices, such as highly-reflective, brightly-colored vests and clothing, clean and highly-visible signs and cones. For each device displayed, ask participants when and how the item should be used.
- ▶ Discuss company policy for notifying police, distance to park vehicles from traveled roads during work and unattended vehicles.

Discussion

Ask participants to share their most recent experience when working on or near the shoulder. What traffic control devices were used? Were these controls appropriate based on the information on pages 8-10 of *Motor Vehicle Safety*?

Review the charts for Work Sign Spacing on pages 9 and 10 of *Motor Vehicle Safety*.

Problem Solving

Display and discuss the overhead “Work Sign Spacing Near the Shoulder” on page 58 of the Instructor Guide. Work out the problem and write the solution on an overhead, chalkboard or flipchart. (When participants are working near the shoulder of an urban road with a speed limit of 50 mph, how many feet should the first road work sign be from the work area? ANSWER: 350 feet)

Problem Solving

Display and discuss the overhead “Work Sign Spacing With the Shoulder Closed” on page 59 of the Instructor Guide. Work out the problem and write the solution on an overhead, chalkboard or flipchart. (When participants are working on the shoulder of a highway with 10 foot lanes and a posted speed limit of 50 mph, how many feet should the shoulder taper be? ANSWER: about 167 feet)

Hands-on Exercise

In a safe area, such as a private road or parking lot on the company’s property, have participants set up a roadside work area using traffic cones and flaggers, as appropriate. Ensure all participants wear brightly-colored reflective vests and any other safety equipment that the organization requires for this type of work.

Evaluation

Answer the quiz items on page 11 of *Motor Vehicle Safety* individually or as a class. Be sure to discuss each item.

Lesson 3

Safety Starts Before the Engine

Suggested Objectives

- Recall safe start up and shut down procedures of your vehicle.
- Recognize how to safely park on hills.

Ask a volunteer to read and discuss the Accident Report on page 12 of *Motor Vehicle Safety*.

Discussion Items

- What is the company policy for daily safety inspection?
- Discuss any problems participants found in the last week while performing daily start-up inspections. What steps were taken to fix these problems? Could these problems have caused serious injury or death had they not been fixed?

Visual Aid

Display and discuss the overhead “Safety Belts Save Lives” provided on pages 60 of the Instructor Guide. Ask participants to discuss and answer the fill-in the blank items. (ANSWER KEY: half, hips, neck, face)

Analysis

Instruct participants to look at the safe starting and shut-down on pages 13-14 of *Motor Vehicle Safety*. Ask them to write a (+) sign next to the procedure if they usually do it and a (-) sign if they seldom do it. Discuss the procedures that are hardest to do.

Visual Aid

Display and discuss overheads of “How To Park On Hills” provided on pages 61-63 of this manual. Ask participants to write the numbers 1-3 in the column on the right side of page 13 of *Motor Vehicle Safety*. For each item, display the overhead and ask participants to write “a” or “b” to identify the correct wheel position. Participants can check their answers with the answer key provided on page 64 of the Instructor Guide. Be sure to discuss each item.

Visual Aid

Display and discuss overhead “What’s Wrong With This Picture?” provided on page 65 of the Instructor Guide. Ask participants to identify and discuss all safety problems in the overhead. Check participants answers with the answer key provided on page 66 of the Instructor Guide.

Evaluation

Answer the quiz items on page 15 of *Motor Vehicle Safety* individually or as a class. Be sure to discuss each item.

Hands-on Exercise

As a group or individually, inspect a motor vehicle using a checklist such as the Daily Pre-Operation Inspection on page 70 of the Instructor Guide.

Protect Yourself While Driving

Lesson 4

Suggested Objectives

- Recognize factors that contribute to motor vehicle crashes.
- Identify ways to prevent crashes.
- Interpret the meaning of traffic signs.

Discuss Accident Reports on pages 16-17 of *Motor Vehicle Safety*.

Discussion

Ask participants to look at the protect yourself tips on page 17 of *Motor Vehicle Safety*. Can participants recall a close call or accident they witnessed that relates to one of these tips?

Discuss the Traffic Signs on page 18 of *Motor Vehicle Safety*.

Contest

Divide the class into groups. Display the contest items provided on pages 67-68 of the Instructor Guide. In turn, ask each group a multiple choice or true/false question from the overheads. Each group gets one point for every correct answer. If a group misses a question, allow the next group to answer it for a point. Keep track of points and recognize the winning group. Use the questions as opportunities to discuss the training material. Answer key provided on page 69 of the Instructor Guide.

Discussion Items

- ▶ What distractions do participants experience while driving motor vehicles?
- ▶ How can they work to minimize and eliminate distractions in motor vehicles?

Discuss pavement markings on page 20 of *Motor Vehicle Safety*.

Case Studies

Break the class into small groups of three to five participants. Provide each group with one of the scenarios from pg 72-74 of the Instructor Guide. Ask each group to answer the question in their scenario, using the information in Lesson 4 of *Motor Vehicle Safety*. If there are more than three groups, have more than one group work on the same scenario. Monitor the progress of the groups. Bring the class back together and ask for a representative from each group to read their problem and explain their solution. Ask other groups what they think of the proposed solution.

Visual Aid

Display a Slow Moving Vehicle Emblem (SMV). Ask participants to list actual situations when an SMV is needed on their jobs. List ideas on an overhead or flipchart.

Evaluation

Answer the quiz questions on page 21 of *Motor Vehicle Safety* individually or as a class. Be sure to discuss each item.

Lesson 5

Operating Large Trucks

Suggested Objectives

- Identify safe loading and unloading procedures.
- Recognize safe operating procedures when driving big trucks.

Discuss Accident Reports on page 22-23 of *Motor Vehicle Safety*.

Questioning

Ask participants: How much longer does it take to stop a heavy truck than it does a passenger vehicle traveling at the same speed?

Discussion Items

- ▶ Discuss safety issues with the loads participants carry. What types of loads do they carry? What are the hazards? What precautions do they take?
- ▶ Divide the class into 3 groups. Assign each group a section from Lesson 5. Ask each group to discuss an example from their own experience that relates to their section. Have each group report back for a class discussion.

Discuss Accident Reports on page 24-25 of *Motor Vehicle Safety*.

Analysis

Have each participant circle the items they always follow from the safe dumping checklist on page 25 of *Motor Vehicle Safety*. As a group, discuss the items that are hardest to do.

Evaluation

Answer the quiz questions on page 26 of *Motor Vehicle Safety* individually or as a class. Be sure to discuss each item.

Hands-on Exercise

In a safe area with adequate supervision, have each participant complete a hands-on exercise with a dump truck by following the safe dumping checklist on page 25 of *Motor Vehicle Safety*.

Questioning/Discussion

Before beginning Lesson 6:

- ▶ Has any participant known someone who has been injured hitching or unhitching a trailer? Would they care to share what happened?

Pulling Trailers

Suggested Objectives

- Recall how to safely hitch and unhitch a trailer
- Interpret safe trailer loading procedures.

Discuss the Accident Report on page 27 of *Motor Vehicle Safety*.

Analysis

Have participants think about the last time they hitched/unhitched a trailer. Using the information under safe hitching and unhitching in Lesson 6 have participants circle the items they followed. As a group discuss any items that were neglected. Ask participants why some items are more difficult to follow and why following them is important.

Visual Aid

- ▶ Use a model vehicle and trailer on sloped surface (such as a board or block) and several small blocks to chock the wheels.
- ▶ Demonstrate to participants how to stabilize the trailer before unhitching, hitching, loading and unloading by blocking the wheels.

Discuss the Accident Report on page 29 of *Motor Vehicle Safety*.

Case Studies

Break the class into small groups of three to five participants. Provide each group with one of the scenarios from pages 75-77 of this manual. Ask each group to answer the question in their scenario, using the information in Lesson 6. If there are more than three groups, have more than one group work on the same scenario. Monitor the progress of the groups. Bring the class back together and ask for a representative from each group to read their problem and explain their solution. Ask other groups what they think of the proposed solution.

Hands-on Exercise

In a safe area with adequate supervision, have participants safely hitch, unhitch, load and unload trailers.

Evaluation

Answer the quiz questions on page 31 of *Motor Vehicle Safety* individually or as a class. Be sure to discuss each item.

Lesson 6

Lesson 7

Environmental Hazards

Suggested Objectives

- Identify environmental hazards.
- Recognize treatment and first aid for exposure to environmental hazards.

Case Studies

Break the class into small groups of three to five participants. Provide each group with one of the scenarios from pages 78-80 of this manual. Ask each group to answer the question in their scenario, using the information in Lesson 7. If there are more than three groups, have more than one group work on the same scenario. Monitor the progress of the groups. Bring the class back together and ask for a representative from each group to read their problem and explain their solution. Ask other groups what they think of the proposed solution.

Discussion Items

- ▶ What job tasks expose participants to frigid winter weather? During these jobs, what parts of their body are most affected by the cold? In their experience, what are most effective ways to prevent hypothermia and frostbite on the job?
- ▶ Have any participants ever had problems with insects, animals or poisonous plants? Would they care to share what happened? What precautions can they take?

Hands-on Exercise

Using your company's first aid kits, demonstrate and have participants practice first aid for cuts, burns, heat exhaustion, cold injury and lightning strike.

Evaluation

Answer the quiz questions on page 38 of *Motor Vehicle Safety* individually or as a class. Be sure to discuss each item.

Conclusion

Contest

Divide the class into groups. Display the contest items provided on pages 81-86 of the Instructor Guide. In turn, ask each group a multiple choice or true/false question from the overheads. Each group gets one point for every correct answer. If a group misses a question, allow the next group to answer it for a point. Keep track of points and recognize the winning group. Use the questions as opportunities to discuss the training material. Answer key provided on page 87 of the Instructor Guide.

Discussion

Ask participants to share any questions or concerns they may still have or want to discuss further.

Evaluation

Answer the quiz questions on page 40 individually or as a group. Be sure to discuss each item.

Hands-on Performance Evaluation

In a safe area with adequate supervision, have each participant complete a hands-on performance evaluation while operating a motor vehicle (including a trailer, if appropriate). The evaluation may include completing:

- ✓ Pre-Operation Inspection provided on page 70 of the Instructor Guide
- ✓ Hitching and Unhitching
- ✓ Safe start-up
- ✓ Driving the vehicle, with trailer, if appropriate, to perform a safe task
- ✓ Loading and Unloading
- ✓ Safe shut-down

A checklist for the performance evaluation is provided on page 71 of the Instructor Guide.

Work Sign Spacing Near the Shoulder

(Urban Road – speed limit 50 mph)

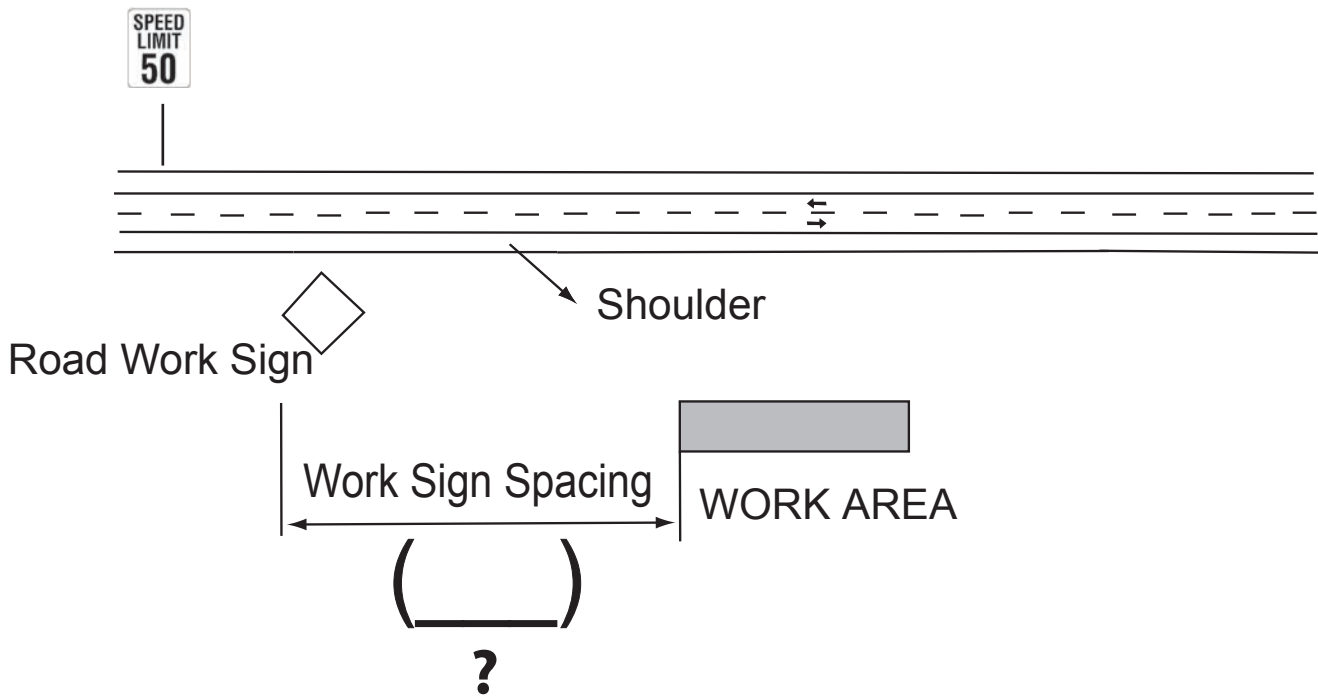

Work Sign Spacing with the Shoulder Closed

(Urban Road – speed limit 50 mph – 10 ft lanes)

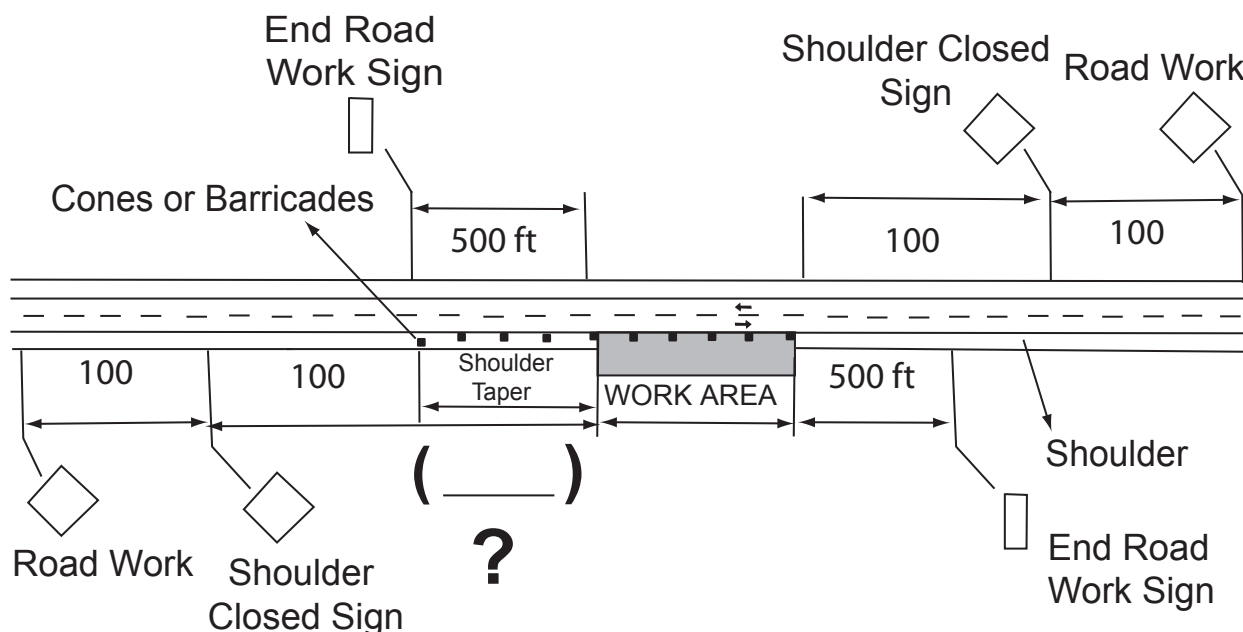

Safety Belts Save Lives

Wearing your safety belt cuts your risk of being killed in a vehicle accident by

To provide protection, the lap portion of the safety belt must be worn low and snug across the _____, and the shoulder portion must be snug across the chest, away from the _____ and _____. Adjust your seat to ensure your safety belt is worn properly.

Facing UPHILL With Curb

A)

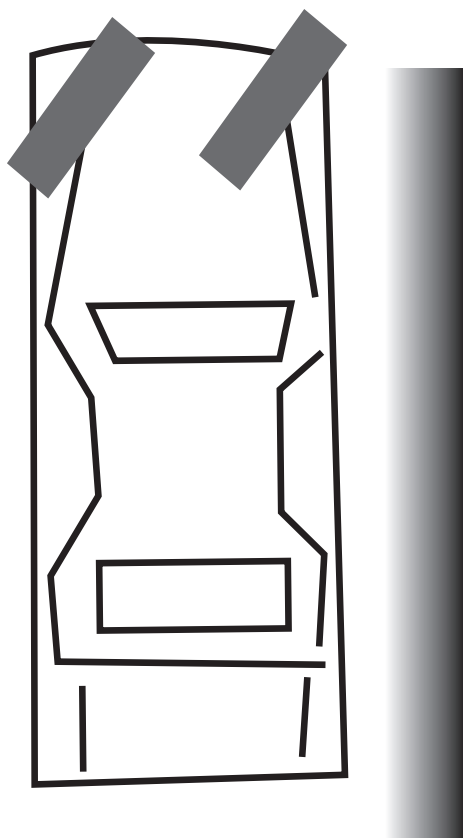

B)

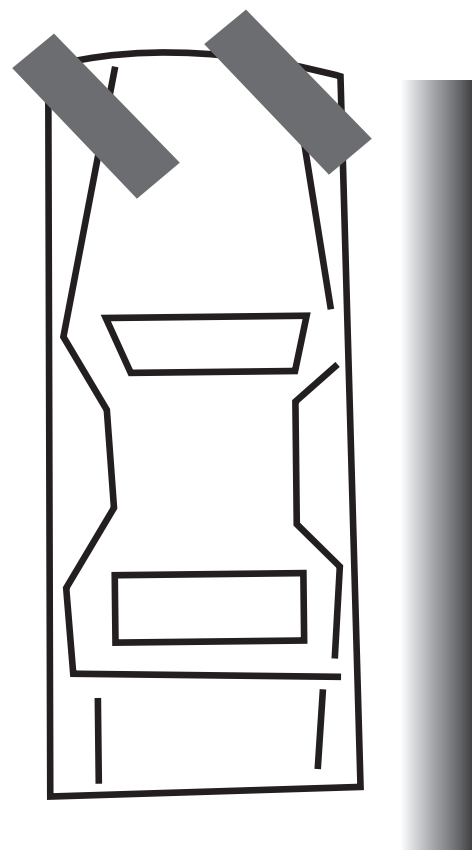

Facing DOWNHILL With or Without a Curb

A)

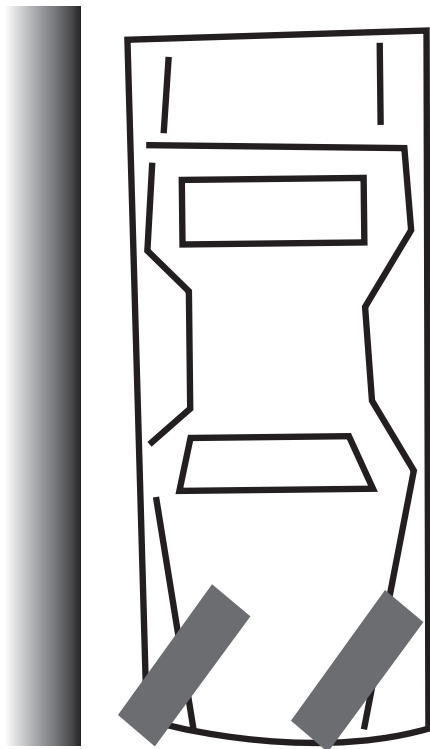

B)

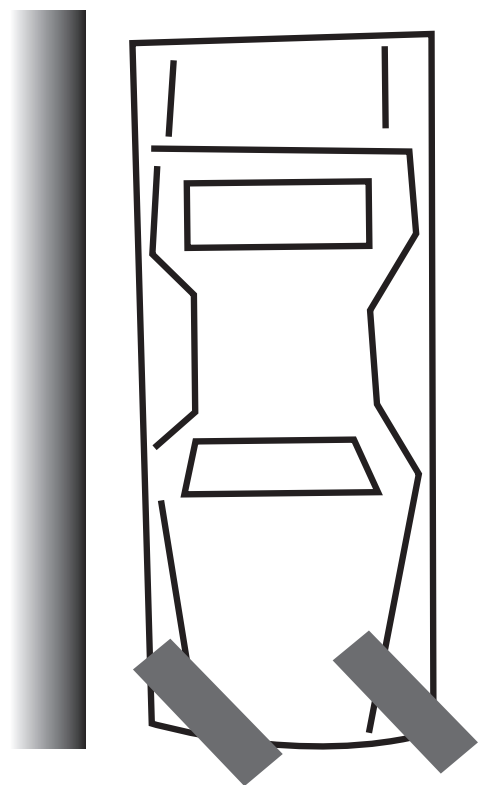

Facing UPHILL Without a Curb

A)

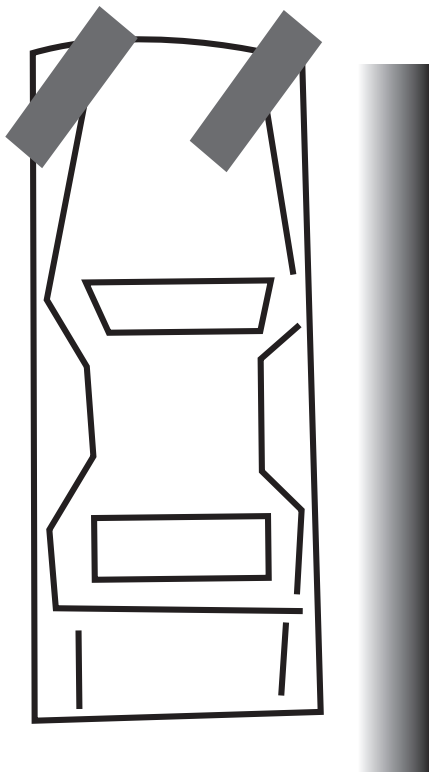

B)

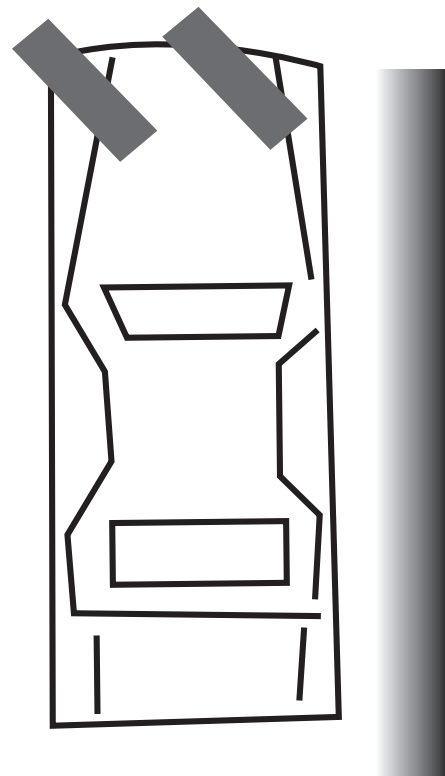

**Facing UPHILL
With Curb**

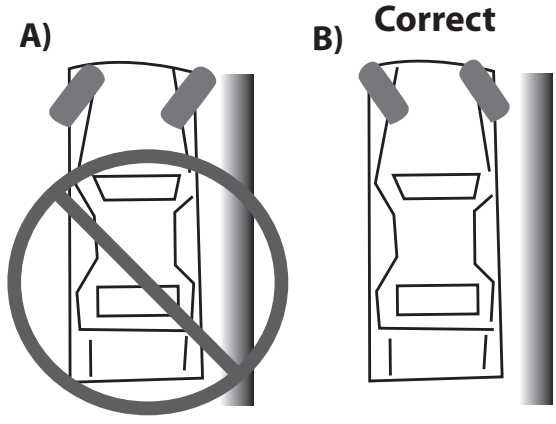

**Facing DOWNHILL With or
Without a Curb**

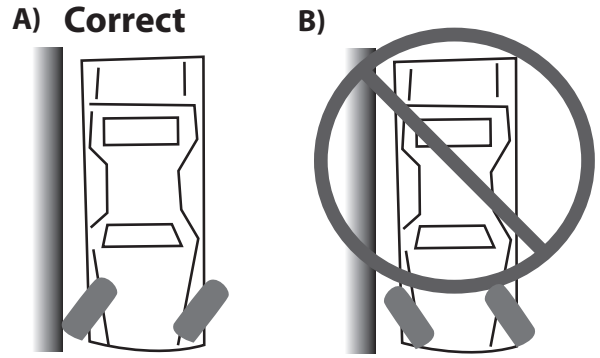

**Facing UPHILL
Without Curb**

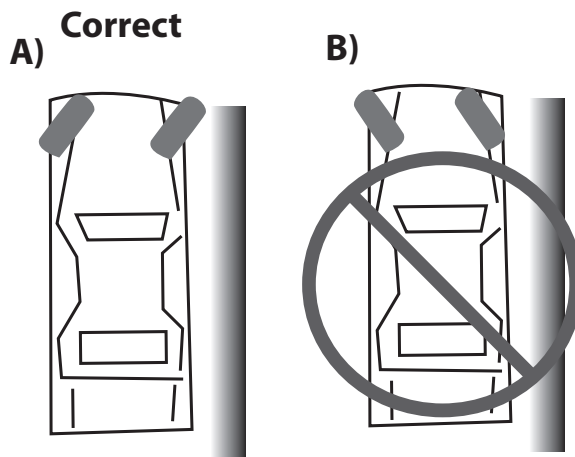

What's Wrong With This Picture?

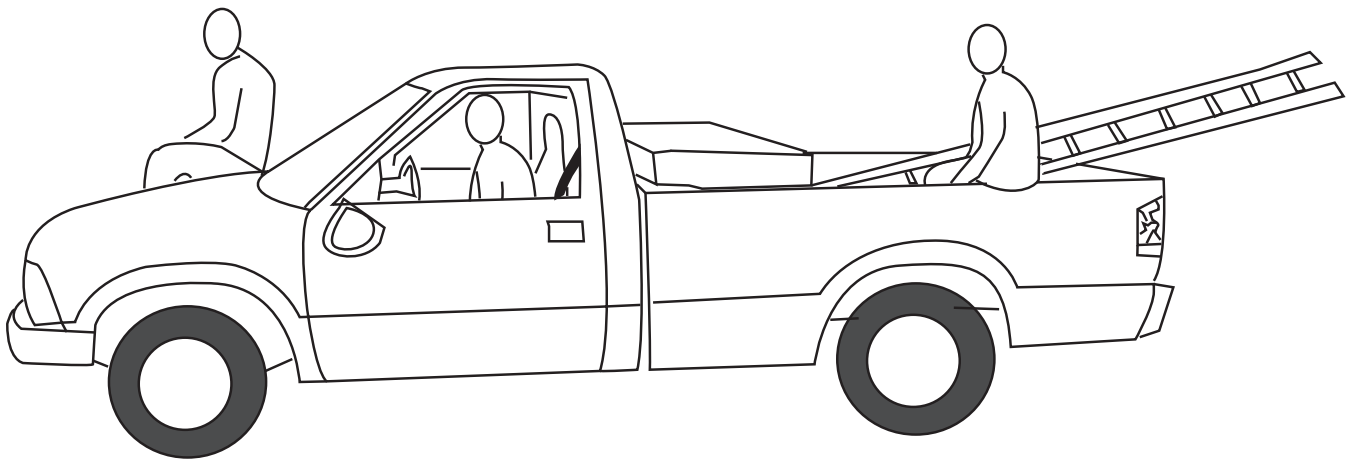

What's Wrong With This Picture?

Do not ride on the hood

Load not flagged or secured

Do not ride in the back of the truck

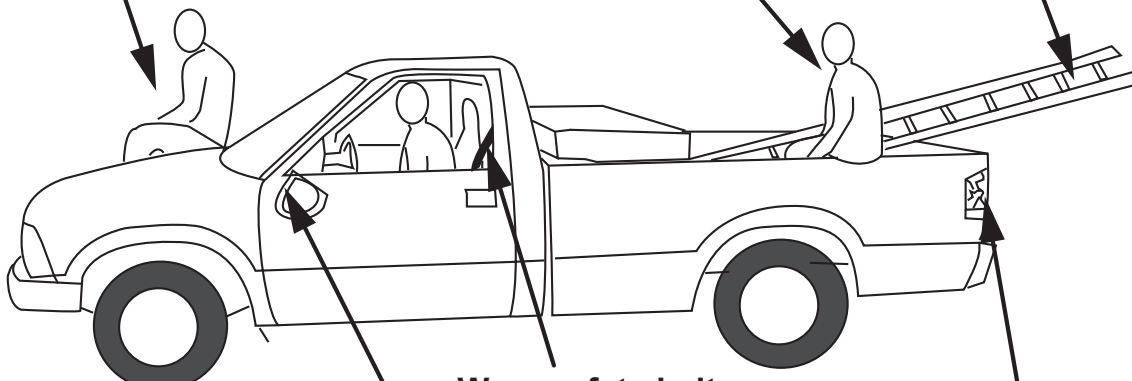

Wear safety belt

Broken tail light

1. The following traffic sign means:



- a. Yield**
- b. Railroad Crossing**
- c. Pedestrian Crossing**

2. Octagon means:

- a. Stop**
- b. Directional Information**
- c. Yield**

3. The following sign shape could mean:

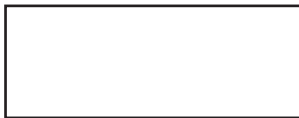

- a. One Way**
- b. Stop**
- c. No Trucks**

4. The following sign shape may indicate:

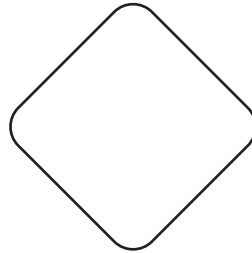

- a. Railroad Crossing**
- b. Pedestrian Traffic**
- c. Men Working**

5. When you see a pennant shaped signs it indicates a No Passing Zone.

True/False

6. Triangle means Merge.

True/False

7. The following sign shape means Stop.

True/False

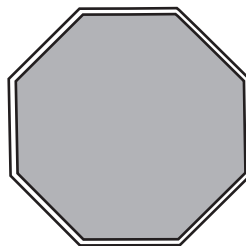

1. b

2. a

3. a

4. c

5. T

6. F

7. T

Daily Pre-Operation Inspection: Motor Vehicle

Operator _____ Date _____

Motor Vehicle ID _____ Make/Model _____

Location: _____

Item	OK	Needs Attention	Specific Comments
Tires			
Fluid Levels			
● Oil			
● Transmission			
● Brake			
● Washer			
Fuel Level			
Driver's License			
Brakes			
Windshields and Mirrors			
Controls			
Safety Belts			

Evaluation/Performance Checklist: Motor Vehicle

Operator: _____ Date: _____

Motor Vehicle ID: _____ Make/Model: _____

Instructor: _____ Location: _____

	Satisfactory	Needs Improvement
Follows Pre-Operation Inspection		
Safe Start Up		
● Clear the area of bystanders		
● Fasten safety belt		
● Transmission in park or neutral as appropriate		
● Start the engine according to manufacturer instructions		
Safe Loading and Unloading		
● Load/Unload on level ground only		
● Use wheel blocks properly		
● Do not overload		
Safe Hitching/Unhitching of Attachments		
● Verify load is within weight limits		
● Block trailer wheels		
● Hitch/Unhitch on level ground only		
● Hitch trailer properly		
● Attach safety chains and fasten lighting connectors		
● Check the brake and signal lights		
● Keep bystanders out of the area		
Demonstrate driving skills		
● Both hands on the steering wheel		
● Obey traffic signals and signs		
● Operate at safe speed		
● Observe safe following distance		
● Use horn when backing		
● Use turn signals and headlights properly		
● Change lanes appropriately		
● Check mirrors before backing		
● Start and stop smoothly		
Safe Shut Down		
● Park on level surface		
● Transmission in park or in appropriate gear		
● Set parking brake		
● Turn off the engine and remove key		
● Lock all doors and roll up windows		

#1 You are driving an older pickup on a busy highway during rush hour in a very heavy rain storm. What issues should you consider, and what precautions should you take?

#2 You are getting ready to leave for a job site early on a snowy winter morning. The job site is more than 50 miles away in a remote, hilly area. What are some issues to consider, and what precautions should you take?

#3 You are driving a truck pulling an empty trailer. The road is snow packed and the wind has picked up. What are some issues to consider, and what precautions should you take?

#1 You have to load gravel on a trailer that is parked on a hill. You are using a front end loader. What issues should you consider, and what precautions should you take before unloading?

#2 You need to load a farm tractor on a flat-bed trailer attached to your truck. What safety issues should you consider?

#3 You will be driving a truck towing a trailer. There is a large farm tractor on the trailer. The tractor's wheels extend beyond the sides of the trailer, making it an over-sized load. You will be traveling on a busy highway after dark. What issues should you consider, and what precautions should you take?

#1 You are in charge of a work crew using dump trucks to haul branches and debris from a tree-trimming project. It is hot and humid. The trucks don't have air conditioning. In the middle of the afternoon, one of the drivers complains of a headache and upset stomach. His face is pale. His skin is moist and clammy. How do you respond? What could have been done to prevent this?

#2 You are in charge of a work crew using trucks to haul sod for a project on the right of way of a busy highway. It is hot and humid. One of your workers has been directing traffic most of the day. You notice he seems agitated and is shouting at passing motorists. When you talk to him he seems very confused. He is not sweating, but his skin is hot and red. How do you respond?

#3 You are using a dump truck to haul trees and branches being cleared from a residential area after a storm. You have an empty truck, and are ready to pick up a new load. The sky is dark and stormy. It begins to rain, and lightning flashes around you. The wind is blowing very hard. You are in the cab of truck. The work crew is outdoors. They have a skid steer loader and a pickup. How do you respond?

- 1. A vehicle that is not traveling over ____ mph must display a Slow Moving Vehicle (SMV) emblem.**
 - a. 25**
 - b. 30**
 - c. 35**

- 2. It takes about _____ the distance to stop a heavy truck as it does a passenger vehicle traveling at the same speed.**
 - a. half**
 - b. equal**
 - c. twice**

- 3. It is _____ safe to transport passengers in the bed of a pickup.**
 - a. sometimes**
 - b. always**
 - c. never**

- 4. You are working beyond the shoulder of the road, but within the right of way. You are working 10 feet from the traveled way. You may use a vehicle with an activated high-intensity rotating light in place of other traffic control devices if your work lasts no more than:**
- a. 60 minutes.**
 - b. 90 minutes.**
 - c. 120 minutes**
- 5. Which is the best practice when working along the shoulder of the road?**
- a. Park your vehicles and equipment as close as possible to the roadway.**
 - b. Notify local police before starting a job that might interfere with traffic flow.**
 - c. Leave warning signs in place and visible when you leave for lunch and when you stop work overnight.**

6. You are working beyond the shoulder of the road, but within the right of way. You will be working more than 60 minutes. You need to use traffic control devices if:

- a. you are working 5 feet from the curb.**
- b. you are working 30 feet from the curb.**
- c. your vehicle is parked on the shoulder.**

7. When driving in fog, turn headlights _____ and use fog lamps, if available.

- a. on high beam**
- b. on low beam**
- c. off**

8. When loading a trailer:

- a. lock the parking brake on the towing vehicle and block the trailer wheels.**
- b. keep bystanders away.**
- c. both A and B.**

9. Help prevent skin cancer by covering exposed skin with a broad spectrum sunscreen that has a Sun Protection Factor (SPF) of at least:

- a. 5**
- b. 10**
- c. 15**

10. You are parked on a hill with no curb. Your vehicle is facing downhill. How should you turn the front wheels?

- a. Turn front wheels toward the roadside.**
- b. Turn front wheels away from the roadside.**
- c. Neither A nor B. Point the wheels straight ahead.**

11. If the truck bed gets stuck in the raised position and won't come down,

_____:

- a. set the brakes**
- b. turn off the engine and remove the key**
- c. block the bed**
- d. all of the above**

12. Yellow pavement markings:

- a. divide same way traffic**
- b. divide two-way traffic**
- c. neither a or b**

13. Which is the best practice when driving in rain?

- a. Speed up when driving through flood waters.**
- b. Use your headlights on low beam.**
- c. Use your headlights on high beam.**

14. Which is the best practice when driving a large truck?

- a. Use your horn when backing, unless the truck has an automatic backup alarm.**
- b. Turn corners sharply when you are hauling water tank trucks.**
- c. Ask passengers to sit quietly in the cargo area.**

15. Lock the parking brake on the towing vehicle before unloading and loading.

True/False

Answer Key

Motor Vehicle Safety Conclusion

1. a

2. c

3. c

4. a

5. b

6. c

7. b

8. c

9. c

10. a

11. d

12. b

13. b

14. a

15. T

Chipper/Shredder Training Guide

Suggested Materials

- Chipper/Shredder Safety* (English, MF2710; Spanish, MF2710S)
- Sign-in sheet
- Pencils
- Instructor Guide
- Training overheads/slides/projector
- Blank overheads/flipchart/blackboard/pen for listing participant responses and outlining important concepts
- Chipper/shredder and tractor for hands-on exercises
- Ear plugs and other protective equipment for hands-on exercises
- First aid kit for hands-on exercises

Sources of Background Information

Chipper/Shredder Safety available for download:

http://www.ksre.ksu.edu/library/landscaping_equipment_safety.htm

Operator's manual for chipper/shredders (available from dealer)

Length of Time Needed for Training

Review and select the learning activities that are most appropriate. If all of the discussion and hands-on exercises are included in the training it may take up to a full work day. Without the hands-on exercises, the classroom portion will take about two hours.

Welcome and Introduction

- ▶ Introduce yourself.
- ▶ Remind participants of the topic of the training.
- ▶ Discuss exit locations, emergency procedures, breaks, locations of restrooms, ending time and any tests or evaluations.
- ▶ Tell participants you expect them to play an active role by relating their experiences and knowledge.

Participant Introductions

Find out:

- ▶ Who are they?
- ▶ What is their experience with chipper/shredders in the workplace?
- ▶ What do they hope to learn from the training?

Questioning/Discussion

Before beginning Lesson 1:

- ▶ Ask participants what types of accidents can happen while operating a chipper/shredder. List ideas on an overhead or flipchart.

Take Charge of Your Own Safety

Lesson 1

Suggested Objectives

- Name the most common types of accidents involving wood chipper/shredders.
- Interpret the meaning of common warning signs and labels.
- Identify appropriate protective equipment.

Discuss Accident Reports on page 4 of *Chipper/Shredder Safety*.

Discussion Items

- ▶ How well did participants' ideas for the most common cause of accidents match those in *Chipper/Shredder Safety*? (Refer to the overhead or flipchart list made during the introduction.)
- ▶ Which of these hazards represents the greatest risk in your workplace?
- ▶ Have any participants known someone who has been seriously injured or killed while operating a chipper/shredder? Would anyone care to share what happened?

Discuss the Safety Signs on page 6 of *Chipper/Shredder Safety*.

- ▶ What signs have participants seen on the equipment in their workplace?

Hands-on Exercise

Have participants inspect and wear any personal protective equipment that is required for their work. Discuss the importance of each item.

Evaluation

As a group, answer the quiz items on page 8. Be sure to discuss each item.

Questioning/Discussion

Before beginning Lesson 2:

- ▶ Ask participants what safety items they check before starting their chipper/shredder every day? List items on an overhead or flipchart.



Inserting Ear Plugs

Try on hearing protection:

- ▶ follow manufacturer's procedure.
- ▶ demonstrate technique.
- ▶ provide feedback as participants practice.

Types of Hearing Protection:

Ear Plugs



- ▶ Clean hands.
- ▶ Roll ear plug between fingers to compress it.
- ▶ Grasp ear from behind your head with opposite hand and pull up to straighten ear canal.
- ▶ Insert ear plug until it blocks sound, then hold in place while it expands. (Count out loud to 20 while it expands.)
- ▶ Ear plug must completely fill ear canal.
- ▶ Test fit by cupping hands over ears and then releasing. There should not be much difference in sound.
- ▶ Wash reusable plugs in warm soapy water after use/throw away disposable after each use.

Hearing Bands



- ▶ Grasp ear from behind your head with opposite hand and pull up to straighten ear canal.
- ▶ Use your hands to press the ear pads into the ear canals.
- ▶ Test fit in a noisy environment: Lightly press band inward and you should not notice much reduction in noise level.

Ear Muffs



- ▶ Make sure the cushions fully cover the ear and seal tightly against the head.
- ▶ Hold the headband at the crown of the head and adjust each cup.
- ▶ Test fit in a noisy environment: Gently push the cups toward your head and release. There should not be much difference in noise level.

Prepare for Safe Operation

Lesson 2

Suggested Objectives

- Indicate features to be inspected before operation.
- Recognize safe operating procedures.
- Identify safe transportation and traffic guidelines.

Discuss the Accident Reports on pages 9-10 of *Chipper/Shredder Safety*.

Discussion

- ▶ How do participants' current pre-operation inspections compare to the one listed in their manual? (Refer to the overhead or flipchart list made at the end of Lesson 1.)
- ▶ Do participants always use a buddy system when working with a chipper/shredder? Why or why not? Why is it important?

Analysis

Ask participants to read information about Safe Startup and Shutdown on page 11 of *Chipper/Shredder Safety*. For each numbered or bulleted point, ask participants to write in the margin if the item mainly protects them from being "caught in moving parts" or "struck by the hood." When everyone has finished have each participant read a point aloud and briefly tell what type of accident it will prevent and why. Be sure to discuss points that participants find surprising or difficult to comply with.

Discuss the Accident Reports on pages 11-12 of *Chipper/Shredder Safety*.

Hands-on Exercise

Have a chipper/shredder available. After completing a pre-operation inspection:

- ▶ Have each participant follow safe startup and shutdown procedures.
- ▶ Ask a participant to demonstrate safe fueling procedures.
- ▶ Ask groups of two or three participants to prepare a chipper/shredder for towing and hitching.

See the Daily Pre-Operation Inspection on page 96 of the Instructor Guide.

Evaluation

Answer the quiz items on page 13 either individually or as a class. Be sure to discuss each item.

Visual Aid

Before beginning Lesson 3:

- ▶ Discuss the overhead "What's Wrong With This Picture?" provided on pages 98 of the Instructor Guide. Ask the group to identify the correct way to feed materials into a chipper shredder.

Lesson 3

Avoid Being Caught in Moving Parts

Suggested Objectives

- Develop safe feeding procedures
- Recognize how to protect yourself from moving parts.

Discuss the Accident Reports on page 15 of *Chipper/Shredder Safety*.

Ask participants to describe how a worker should safely attempt to unclog debris or make adjustments to a chipper.

Analysis

Ask participants to look over items under “Safe Feeding Procedures,” “Moving Parts,” and “PTO Safety.” Have participants circle any items that are hard for them to do on the job. Ask participants to discuss the items they circled; why are they difficult to comply with and what can be done to make them easier to follow?

Discuss the recommendation in the Did You Know? box on page 16 of *Chipper/Shredder Safety*.

Hands-on Exercise

Have a tractor with PTO and chipper. As a group, inspect and discuss the shields and guards. Ensure the shaft is secured. Under careful supervision, have participants practice feeding materials into the chipper/shredder.

- ▶ Be sure all participants are wearing proper protective equipment.
- ▶ Be sure all participants are a safe distance from the chipper/shredder.
- ▶ Demonstrate the correct procedure.
- ▶ Have each participant practice one at a time.

Evaluation

Answer the quiz items on page 17 either individually or as a class. Be sure to discuss each item.

Avoid Being Struck by the Hood

Lesson 4

Suggested Objectives

- Recognize how to prevent injury from the chipper/shredder hood.
- Identify location of the hood on different chipper/shredder models.
- View different warning labels on chipper/shredder hoods.

Discuss the Accident Reports on page 18 of *Chipper/Shredder Safety*.

Discussion Items

- ▶ Have participants ever known of a situation like the ones in the accident reports? Would they care to share what happened?

Discuss the recommendation in “Prevent Injury From The Hood” on page 18 *Chipper/Shredder Safety*.

- ▶ What policies does your company have that relate to inspecting hoods and keeping them closed?
- ▶ What can be done to make compliance easier?

Review the warning labels information on page 19 of the *Chipper/Shredder Safety Manual*

Hands-on Exercise

Break the class into small groups. Have each group examine a chipper/shredder and locate and inspect the hood. Have each group report back to the class regarding the condition of the hood and where it might strike a worker if it flew off.

Evaluation

Answer the quiz items on page 20 either individually or as a class. Be sure to discuss each item.

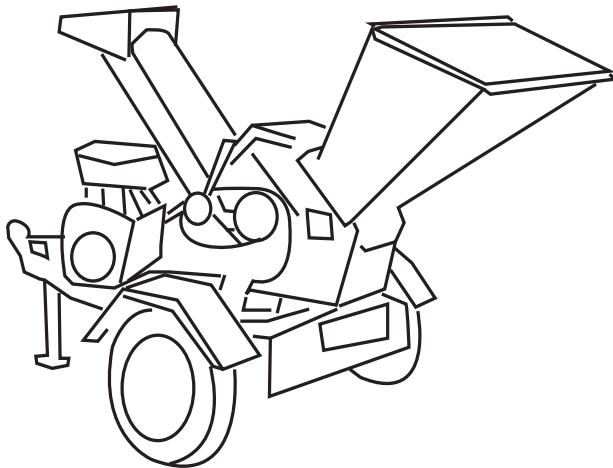

Lesson 5

Environmental Hazards

Suggested Objectives

- Identify environmental hazards.
- Recognize treatment and first aid for exposure to environmental hazards.

Discuss the Accident Report on page 21 of *Chipper/Shredder Safety*.

Discussion Items

- ▶ Have participants experienced or known any one who has suffered heat related illness? If so, would they care to share what happened and how the individual was treated?
- ▶ What could have been done to prevent the illness?

Discuss the Heat Symptoms in the column on page 22 of *Chipper/Shredder Safety*.

Visual Aid

Display and discuss the overhead “What Should You Do?” on page 100 of the Instructor Guide. As a group, discuss the proposed solution.

Contest

Divide the class into groups. Display the contest items provided on pages 101-105 of the Instructor Guide. In turn, ask each group a multiple choice or true/false question from the overheads. Each group gets one point for every correct answer. If a group misses a question, allow the next group to answer it for a point. Keep track of points and recognize the winning group. Use the questions as opportunities to discuss the training material. Answer key provided on page 106.

Hands-on Exercise

Using your company’s first aid kits, demonstrate and have participants practice first aid for common injuries such as cuts and burns.

Evaluation

Answer the quiz items on page 27 either individually or as a class. Be sure to discuss each item.

Conclusion

Discussion

Ask participants to share any questions or concerns they may still have or want to discuss further.

Case Studies

Break the class into small groups of three to five participants. Provide each group with one of the scenarios from pages 107-109 of the Instructor Guide. Ask each group to answer the question in their scenario, using the information in the Chipper/Shredder Safety Manual. If there are more than three groups, have more than one group work on the same scenario. Monitor the progress of the groups. Bring the class back together and ask for a representative from each group to read their problem and explain their solution. Ask other groups what they think of the proposed solution.

Evaluation

Answer the quiz questions on page 29 individually or as a group. Be sure to discuss each item.

Hands-on Performance Evaluation

In a safe area with adequate supervision, have each participant complete a hands-on performance evaluation while operating a chipper/shredder. The evaluation may include completing:

- ✓ Pre-Operation Inspection provided on page 96 of the Instructor Guide
- ✓ Safe start-up
- ✓ Proper feeding procedures
- ✓ Safe shut-down.

A checklist for the performance evaluation is provided on page 97 of the Instructor Guide.

Daily Pre-Operation Inspection: Chipper/Shredder

Operator _____ Date _____

Chipper/Shredder ID _____ Make/Model _____

Location: _____

Item	OK	Needs Attention	Specific Comments
Machine Placement <ul style="list-style-type: none"> ● On level surface ● Not on paved, concrete or gravel surface 			
Safety Decals <ul style="list-style-type: none"> ● Legible 			
Guards <ul style="list-style-type: none"> ● All guards in place ● No sign of damaged guards 			
Hoods <ul style="list-style-type: none"> ● Closed ● Latched ● Pins in place ● Hinges not damaged 			
Cutting Chamber <ul style="list-style-type: none"> ● Free of foreign objects ● Free of wood and other debris 			
Fluid Leaks			
PTO <ul style="list-style-type: none"> ● Properly hitched ● Shaft fitted with suitable guard ● Speed suitable for machine 			

Evaluation/Performance Checklist: Chipper/Shredder

Operator: _____ Date: _____

Chipper/Shredder ID: _____ Make/Model: _____

Instructor: _____ Location: _____

	Satisfactory	Needs Improvement
Follows Pre-Operation Inspection		
Safe Start Up		
● Remove any tripping hazards		
● Clear the area of bystanders		
● Start the chipper/shredder at the lowest possible speed		
● Listen for noise or vibration		
● Follow the operator’s manual procedures		
PTO Precautions		
● Properly hitched		
● On level ground		
● Tractor in neutral, with parking brake set		
● Start tractor, engage PTO and then increase to recommended RPM		
Safe Feeding Procedures		
● Feed material at full operating speed		
● Feed branches from the side of chute		
● Keep hands and feet outside the chute, use a push stick, if necessary		
● Let go of material as soon as it begins to be pulled in		
● Feed the branches butt end first		
● Shorter materials on top of longer materials		
● Collect small materials and put them with chipped material		
Safe Shut Down		
● Disconnect power supply		
● Remove key		
● Follow the operator’s manual procedures		

What's Wrong With This Picture?

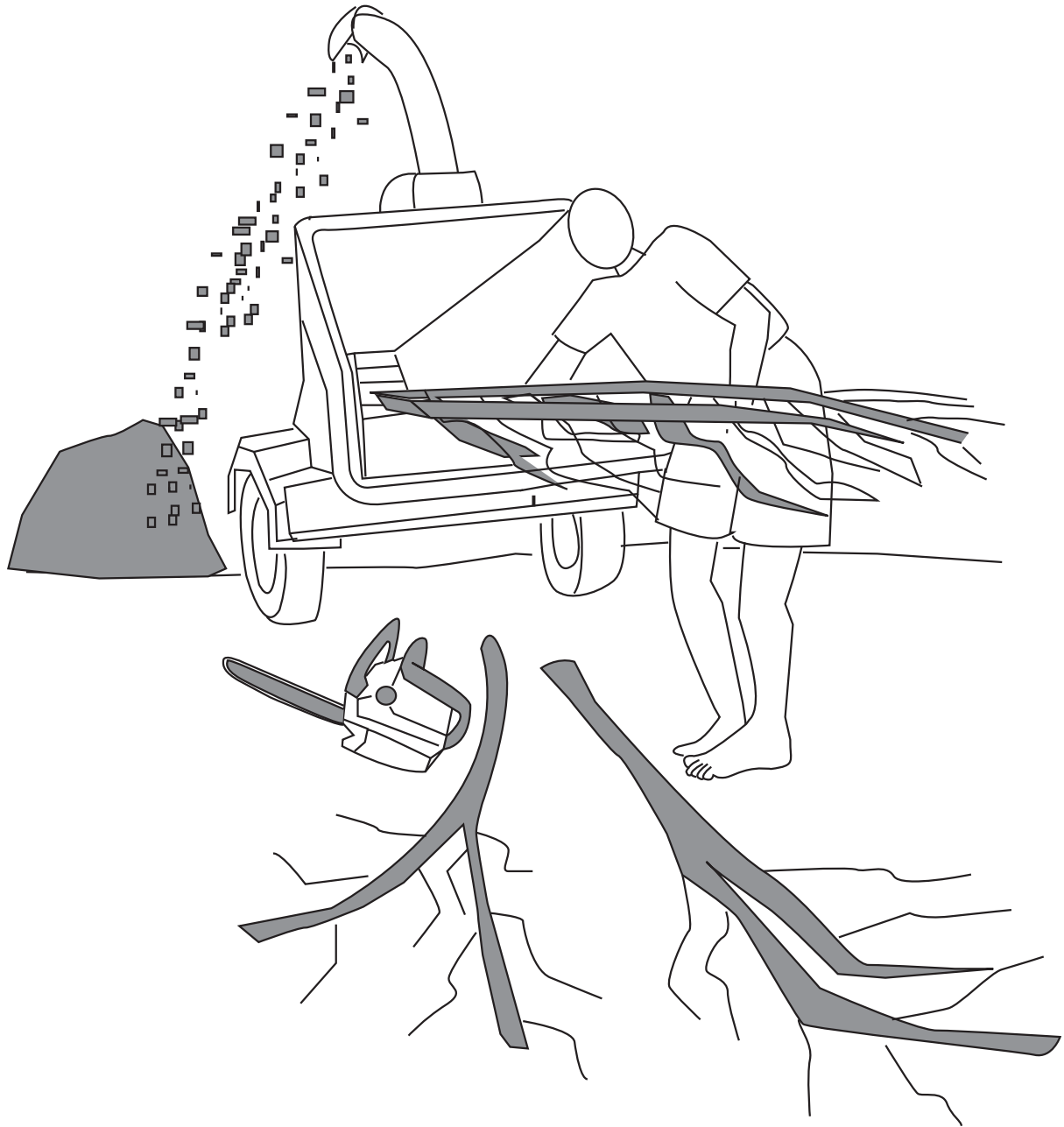

What's Wrong With This Picture?

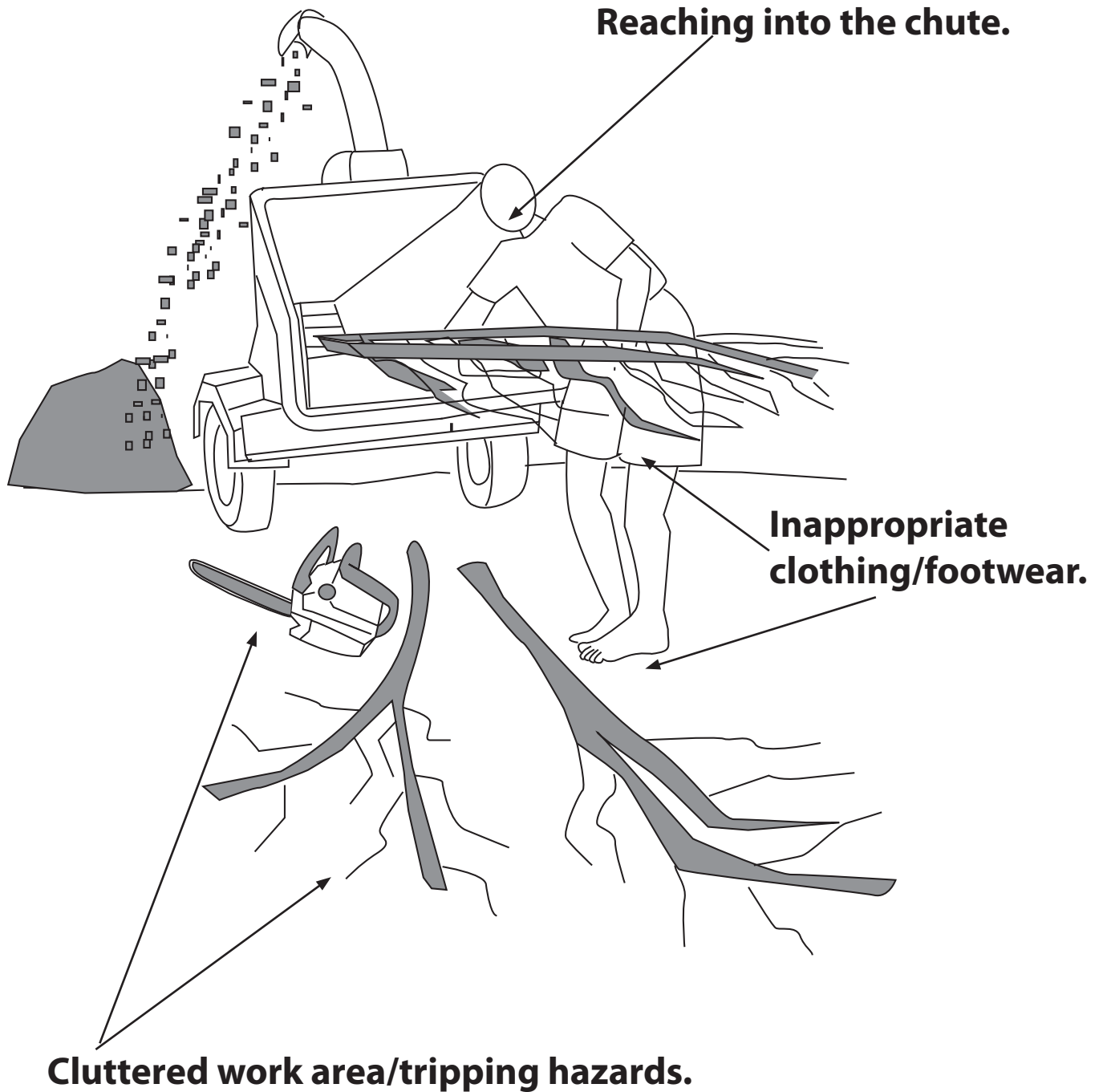

What Should You Do?

You and a coworker are operating a chipper on a hot summer afternoon, when your coworker complains of a headache. He is very sweaty and barely has the energy to feed material in the chipper. What should you do?

- 1. To avoid heat illness:**
 - a. drink at least a quart of water per hour.**
 - b. plan to do the most strenuous work in the coolest part of the day.**
 - c. both A and B.**

- 2. It is a hot day, and your co-worker becomes light headed, dizzy and has clammy, moist skin. How should you respond?**
 - a. Move the person to a cool area and give fluids to drink.**
 - b. Cover the person with a warm blanket.**
 - c. Give the person salt tablets.**

- 3. A broad spectrum sunscreen with a Sun Protection Factor of at least 15 will help protect you from:**
 - a. cataracts.**
 - b. skin cancer.**
 - c. neither A nor B.**

- 4. Sunglasses and a hat with a visor will help protect you from:**
- a. cataracts.**
 - b. near-sightedness.**
 - c. neither A nor B.**
- 5. It is a hot day, and your co-worker becomes disoriented, confused, and has hot, dry, red skin. How should you respond?**
- a. Give the person a soda and wait for 30 minutes to see if s/he starts feeling better.**
 - b. Call 911 immediately and take steps to cool the person's body temperature.**
 - c. Keep the person warm until help can arrive.**

- 6. Which of the following is the best practice to avoid being struck by lightning?**
- a. Crawl under a vehicle.**
 - b. Lie flat on the ground under a large tree.**
 - c. Get indoors as soon as you hear thunder or see lightning.**
- 7. Which of the following is the best practice for working in cold weather?**
- a. Work alone.**
 - b. Dress in layers of warm clothing.**
 - c. Vigorously rub any skin that becomes numb and turns a pale white color.**
- 8. You should consult a physician if:**
- a. you are bitten by a snake.**
 - b. you have poison ivy on the face, mouth or a large portion of the body.**
 - c. both A and B.**

- 9. How should you respond if someone working in cold wather becomes drowsy, has bluish-colored skin, and is shivering uncontrollably?**
- a. Make the person warm and dry, and seek medical attention immediately.**
 - b. Tightly wrap the person in cool, wet towels.**
 - c. Give the person alcoholic beverages to drink.**
- 10. Lightning can strike the same place twice.
True/False**
- 11. A person who has been struck by lightning retains an electric charge that can shock you.
True/False**

12. You are more vulnerable to heat illness if you have suffered it in the past.

True/False

13. It may take a new worker anywhere from 5 days to 2 weeks to be acclimated to working in the heat.

True/False

14. You are more likely to suffer from a heat-related illness on days with LOW humidity.

True/False

15. Use a cold pack on an insect sting during the first 24 hours to relieve pain and swelling.

True/False

1. c

9. a

2. a

10. T

3. b

11. F

4. a

12. T

5. b

13. T

6. c

14. F

7. b

15. T

8. c

#1 You are in charge of a work crew that will be working in a sparsely populated area 20 miles from the nearest town. You will be traveling to this area each day for about two weeks. Your crew will be using a PTO-powered chipper/shredder to grind branches as they are being trimmed away from powerlines. What safety issues should you consider?

#2 You have to operate a chipper near a busy roadway. What issues should you consider and how can you protect yourself, coworkers and motorists?

#3 You will be operating a chipper in a popular public park. What issues should you consider and what precautions should you take?

Skid Steer Loader Safety Training Guide

Suggested Materials

- Skid Steer Loader Safety* (English, MF2711; Spanish, MF2711S)
- Sign-in sheet
- Pencils
- Instructor Guide
- Training overheads/slides/projector
- Blank overheads/flipchart/blackboard/pen for listing participant responses and outlining important concepts
- Skid steer loader/attachments for hands-on exercises
- Ear plugs and other protective equipment for hands-on exercises
- First aid kit for hands-on exercises

Sources of Background Information

Skid steer and motor vehicle safety training manuals available for download:

http://www.ksre.ksu.edu/library/landscaping_equipment_safety.htm

Operator's manuals for skid steer loaders (available from dealer)

Length of Time Needed for Training

Review and select the learning activities that are most appropriate. If all of the discussion and hands-on exercises are included in the training it may take up to a full work day. Without the hands-on exercises, the classroom portion will take about two hours.

Welcome and Introduction

- ▶ Introduce yourself.
- ▶ Remind participants of the topic of the training.
- ▶ Discuss exit locations, emergency procedures, breaks, locations of restrooms, ending time and any tests or evaluations.
- ▶ Tell participants you expect them to play an active role by relating their experiences and knowledge.

Participant Introductions

Find out:

- ▶ Who are they?
- ▶ What is their experience with skid steer loaders?
- ▶ What do they hope to learn from the training?

Questioning/Discussion

Before beginning Lesson 1:

- ▶ Ask participants what they believe are the most common types of accidents that happen with skid steer loaders. List ideas on an overhead or flipchart.
- ▶ Have any participants known someone who has been killed or seriously injured in a skid steer accident? Would they care to share what happened?

Take Control of Your Own Safety

Lesson 1

Suggested Objectives

- List the two most commonly reported causes of death from skid steer loaders.
- Interpret the meaning of commonly posted warning signs.

Discuss Accident Reports on pages 4-5 of *Skid Steer Loader Safety*.

Visual Aid

- ▶ Display and discuss the overhead “Deaths Involving Skid Steer Loaders” on page 119 of the Instructor Guide. (These percentages represent the combined results of 2 studies of 91 deaths involving skid steer loaders. Studies were conducted by the National Institute for Occupational Safety and Health.)
- ▶ Refer to list of participants’ ideas about the most common causes of accidents on skid steer loaders. How well do participant’s ideas match the actual cases of death? Are participants surprised by any of the most common types of accidents?

Discuss the Safety Signs on page 6 of *Skid Steer Loader Safety*.

Can participants recall any safety signs they have seen on equipment?

Evaluation

As a group, answer the quiz items on page 7 of *Skid Steer Loader Safety*. Be sure to discuss each item.

Questioning/Discussion

Before beginning Lesson 2:

- ▶ Ask participants what safety items they check before starting the skid steer loader each day. List their responses on a flipchart or overhead.
- ▶ What precautions do they take when they shut down the skid steer loader and leave it unattended?

Lesson 2

Prepare for Safe Operation

Suggested Objectives

- Identify and locate safety related features you must check each day before startup.

Discuss the Pre-Start Inspection information and Checklist on page 8-9 of *Skid Steer Loader Safety*.

Discussion Items

- ▶ How well did participants' list of safety items they check before starting the skid steer loader each day match those in *Skid Steer Loader Safety*? (Refer to the overhead or flipchart list made at the end of lesson 1.)
- ▶ Discuss your company's policy for recording pre-start equipment checks.
- ▶ Do all of the company's skid steer loaders have safety features that keep the lift arms and attachments from moving when the operator is not in the driver's seat? Have any of these safety features been disabled?
- ▶ Discuss your company's policy for safety belt use.

Analysis

Ask participants to silently read "Safe Start and Shut Down" on pages 9-11 of *Skid Steer Loader Safety*. For each numbered or bulleted item, ask participants to write a "C" in the margin if the item mainly protects them from being crushed by moving parts. Write an "R" in the margin if the item mainly addresses being run over. Write a "B" in the margin if the item mainly addresses both of these hazards. Write an "O" in the margin if the item mainly addresses other hazards. When everyone has finished, have each participant read an item and briefly tell what type of accident it will prevent and why. Be sure to discuss items that participants find surprising or difficult to comply with.

Discuss the Accident Reports on pages 10-11 of *Skid Steer Loader Safety*.

Evaluation

Individually or as a group, answer the quiz items on page 12 of *Skid Steer Loader Safety*. Be sure to discuss each item.

Hands-on Exercises

- ▶ As a group or individually inspect a skid steer loader using a checklist such as the Pre-Operation Inspection on page 120 of the Instructor Guide.
- ▶ Have each participant safely mount, start, shut down, and dismount a skid steer loader, observing the precautions on pages 9-11 of the Skid Steer Safety Manual. (Instruct participants about the operating controls and keep everyone out of the way.)
- ▶ Hitch and unhitch equipment that participants will be expected to use.
- ▶ Discuss other procedures that may be relevant for other types of skid steer loaders.

Don't Get Crushed by Moving Parts

Suggested Objectives

- Recognize how moving parts can crush you.
- Identify safe work practices that protect you from being crushed.

Discuss the Accident Reports on pages 13-14 of *Skid Steer Loader Safety*.

Case Studies

Break the class into small groups of three to five participants. Provide each group with one of the scenarios on pages 122-125 of this Instructor Guide. Ask each group to discuss their scenario, using the information from Lesson 3 of *Skid Steer Loader Safety*. If there are more than four groups, more than one group can work on the same scenario. Monitor the progress of each group. Bring the class back together and ask for a representative from each group to read their problem and explain their solution. Display case study overheads as each group takes turns. Ask other groups what they think of the proposed solution.

Hands-on Exercise

Show the class one or more skid steer loaders (parked and properly shut down). Ask participants to point out locations where they could be crushed by moving parts while operating the loader. Locate data plates and load capacities for the skid steer loader(s). Demonstrate the proper use of the safety belt and bar.

Evaluation

Answer the quiz items on page 16 of *Skid Steer Loader Safety*. Be sure to discuss each item.

Lesson 3

Lesson 4

Prevent Rollover Accidents

Suggested Objectives

- Identify safe work procedures to avoid rollover accidents.
- Describe what could happen when safety procedures are not followed.

Discuss the Accident Reports on pages 17-19 of *Skid Steer Loader Safety*.

Discussion

- Discuss the load capacities and locations of data plates of the skid steer loaders used by the company.

Case Studies

Break the class into small groups of three to five participants. Provide each group with one of the scenarios on pages 126-128 of this Instructor Guide. Ask each group to discuss their scenario, using the information from Lesson 4 of *Skid Steer Loader Safety*. If there are more than three groups, more than one group can work on the same scenario. Monitor the progress of each group. Bring the class back together and ask for a representative from each group to read their problem and explain their solution. Display case study overheads as each group takes turns. Ask other groups what they think of the proposed solution.

Visual Aid

Display and discuss the overheads of skid steer loaders on pages 129-134. Ask participants to identify the safer way to operate the skid steer loader to avoid a rollover. Answer key provided on page 135.

Evaluation

As a group, answer the quiz items on page 21 of *Skid Steer Loader Safety*. Be sure to discuss each item.

Other Operational Hazards

Lesson 5

Suggested Objectives

- Describe how to avoid collisions with obstacles, traffic and people.
- Identify dangers from electricity, carbon monoxide, fuels and other fluids as well as falling material.

Discuss the Accident Report on page 22 of *Skid Steer Loader Safety*.

Discussion Items

- ▶ Do any participants know of someone who has been run over by a skid steer loader or other equipment? Would they care to share what happened?
- ▶ For the kind of work your company does, what tasks carry the greatest risk of someone getting run over?
- ▶ Discuss your company's practices regarding moving loads that block the driver's view.
- ▶ Discuss any hand signals used by drivers, guides and spotters.
- ▶ Discuss your company's policy regarding extra riders on skid steer loaders.
- ▶ Discuss any recommendations under the heading "Steer Clear of Runover Accidents" on pages 22-23 that haven't already been covered.

Discuss the Accident Report on page 23 of *Skid Steer Loader Safety*.

- ▶ Do any participants know of someone who has been injured or killed because they collided with an obstacle while driving a skid steer loader? Would they care to share what happened?
- ▶ Where at work are participants at greatest risk of having a collision? What can be done to minimize collisions?
- ▶ Discuss undercutting. Do participants remove bulk materials from large piles? If so, what precautions do they take?
- ▶ Discuss your company's policies and practices regarding checking for and repairing hydraulic fluid leaks.

Discuss the Accident Report on page 24 of *Skid Steer Loader Safety*.

- ▶ Do participants use skid steer loaders indoors? If so, what precautions do they take to prevent carbon monoxide poisoning?
- ▶ Discuss your company's policy regarding work near power lines and calling the utility location hotline before digging.
- ▶ What do you do if your skid steer loader comes in contact with a power line?

Evaluation

Answer the quiz items on page 26 of *Skid Steer Loader Safety* either individually or as a class. Be sure to discuss each item.

Hands-on Exercise

- ▶ Take the class outdoors and point out several specific locations (roadside, warehouse, field, residential area). Break the class into groups of three to five participants. Ask each group to evaluate one of the areas and report back to the class regarding any precautions that are necessary in order to prevent an accident involving a roll over, runaway, collision with obstacles, traffic, carbon monoxide or electricity.
- ▶ In a safe area such as a private road or parking lot on the company's property, have participants set up a roadside work area using traffic cones and flaggers, as appropriate. Make sure all participants wear brightly-colored reflective vests and any other safety equipment that the organization requires for this type of work. Guidelines for roadside work areas are detailed in *Motor Vehicle Safety for the Landscape and Horticultural Services Industry* (MF2709) at http://www.ksre.ksu.edu/library/landscaping_equipment_safety.htm
- ▶ With the class observing, ask one of the participants to demonstrate how to safely fuel a skid steer loader. Why is it important to touch the fuel nozzle to the loader before opening the fuel cap?

Environmental Hazards

Lesson 6

Suggested Objectives

- Identify environmental hazards.
- Recognize treatment for first aid for exposure to environmental hazards.

Case Studies

Break the class into small groups of three to five participants. Provide each group with one of the scenarios on pages 136-138 of this Instructor Guide. Ask each group to discuss their scenario, using the information from Lesson 6 of *Skid Steer Loader Safety*. If there are more than three groups, more than one group can work on the same scenario. Monitor the progress of each group. Bring the class back together and ask for a representative from each group to read their problem and explain their solution. Display case study overheads as each group takes turns. Ask other groups what they think of the proposed solution.

Discussion

- ▶ When using a skid steer loader in frigid winter weather, what body parts are most likely to be injured by the cold? Why? In their personal experience, what actions have participants found most effective for preventing cold-induced injury?

Discussion

- ▶ Have any participants had a bad experience with insects, animals or poisonous plants while working at their jobs? Would they care to share what happened?

Evaluation

Answer the quiz items on page 33 of *Skid Steer Loader Safety* either individually or as a class. Be sure to discuss each item.

Hands-on Exercise

Using your company's first aid kits, demonstrate and have participants practice first aid for common injuries such as cuts and burns.

Conclusion

Contest

Divide the class into groups. Display the contest items provided on pages 139-145 of the Instructor Guide. In turn, ask each group a multiple choice or true/false question from the overheads. Each group gets one point for every correct answer. If a group misses a question, allow the next group to answer it for a point. Keep track of points and recognize the winning group. Use the questions as opportunities to discuss the training material. Answer key provided on page 146 of the Instructor Guide.

Discussion

Ask participants to share any questions or concerns they may still have or want to discuss further.

Evaluation

Answer the quiz questions on page 35 of *Skid Steer Loader Safety* individually or as a group. Be sure to discuss each item.

Hands-on Performance Evaluation

In a safe area with adequate supervision, have each participant complete a hands-on performance evaluation while operating a skid steer loader (including attachments, if appropriate). The evaluation may include completing:

- ✓ Pre-Operation Inspection provided on page 120 of the Instructor Guide
- ✓ Connecting attachments
- ✓ Safe start-up
- ✓ Driving the loader, to perform a safe task
- ✓ Removal of attachments
- ✓ Safe shut-down

A checklist for the performance evaluation is provided on page 121 of the Instructor Guide.

Deaths Involving Skid Steer Loaders

59% = Pinned/crushed between bucket and frame or between lift arms and frame

19% = Rollover

16% = Crushing incidents with no further information provided

2% = Pinned/crushed between loader and another object

1% = Run over

2% = Other/Unknown

Composite results of two government studies involving a total of 91 deaths reported in National Institute for Occupational Safety and Health Publication Number 98-117

Daily Pre-Operation Checklist: Skid Steer Loader

Operator: _____ Date: _____

Skid Steer ID: _____ Make/Model: _____

Location: _____

Item	OK	Needs Attention	Specific Comments
Tires <ul style="list-style-type: none"> ● Properly inflated ● No visible damage 			
Cab and Side Screen <ul style="list-style-type: none"> ● No frame damage ● No unauthorized alterations ● Side screen attached properly ● No damage to side screens 			
Safety Belt and Bar <ul style="list-style-type: none"> ● Undamaged ● Working properly 			
Grab Handles <ul style="list-style-type: none"> ● Non-slip grip undamaged 			
Steps <ul style="list-style-type: none"> ● Free from dirt, clutter, snow, ice, etc ● Non-slip surface undamaged 			
Attachments front and/or rear <ul style="list-style-type: none"> ● Attached correctly ● Fastened securely 			
Fluid Leaks <ul style="list-style-type: none"> ● No signs of hydraulic fluid leaks ● No signs of fuel leaks ● No signs of brake fluid leaks 			

Evaluation/Performance Checklist: Skid Steer Loader

Operator: _____ Date: _____

Skid Steer ID: _____ Make/Model: _____

Instructor: _____ Location: _____

	Satisfactory	Needs Improvement
Follows Pre-Operation Inspection		
Safe Entry		
● Engine off		
● Lift arms down and attachments on the ground		
● Use the steps made for entering		
● Do not use control levers as grab bars		
Safe Start Up		
● Safety belt fastened		
● Restraining bar lowered (if so equipped)		
● Controls in neutral and parking brake set		
● Area is clear of bystanders		
● Test all controls		
● Check the brakes		
● Check the horn and backup alarm (if so equipped)		
Demonstrate Driving Skills		
● Operate at safe speed		
● Operate safely on hills		
● Start on stop smoothly		
● Avoid obstacles and hazardous areas		
● Follow safe backing procedures		
● Uses attachments appropriately		
● Handles load appropriately		
Safe Shut Down and Exit		
● Park on level surface		
● Lower the lift arms and attachments to the ground		
● Place the controls in neutral		
● Set the parking brake		
● Turn the engine off		

#1 You are using an older skid steer loader with a front bucket attachment. While lifting a load, the lift arms get stuck in the raised position. One of your coworkers sees that you are having a problem and comes to help. What precautions should be taken regarding: Getting safely out of the loader? Keeping your coworker safe? Repairing the loader?

#2 You are using a loader with a bucket attachment to move dirt around a building foundation. There are lots of trees and shrubs near the foundation, so you are placing the dirt as close as you can, while coworkers on the ground are spreading the dirt with shovels. What issues do you need to consider and what precautions should you take to protect your coworkers?

#3 Your boss sends you to get the skid steer loader. When you get to the equipment shed, you find that someone has been using the loader and didn't shut it down properly. The engine is running, the lift arms and bucket are raised, but you don't see anyone around. What issues do you need to consider and what precautions should you take in order to safely enter and move the loader?

#4 It is winter, and you will be using the skid steer loader. Upon inspection, you see that ice and frozen mud have accumulated under the front of the loader. You believe the loader will be damaged if you try to operate it without first clearing away the ice and mud. The only way to clean the loader is to raise the lift arms and then work underneath. Describe how you will plan this job to make sure no one gets hurt while cleaning under the front of the loader.

#1 You are using a skid steer loader to load trucks with soil and other materials. The soil is stored outside, but some materials are stored in a warehouse. A ramp leads to a raised dock where you will load the trucks. Most of the floor is concrete, but a part is older wood. What issues do you need to consider and what precautions should you take to avoid a rollover accident? What precautions should you take to protect your coworkers?

#2 You are assigned to use a skid steer loader to move logs and brush where trees were recently felled on a hillside. For the most part, the hill has a very gentle slope, but there are a few steep gullies and some uneven ground. Some of the logs are very small, while others are quite large. What issues do you need do consider and what precautions should you take to avoid rollover accidents while operating here?

#3 You need to use a skid steer loader with a fork attachment to unload bundles of landscape timbers from a tractor-trailer. You will be moving the timbers to raised storage racks in a crowded warehouse. There is no loading dock, so the tractor trailer has to be unloaded from the ground on the gravel parking lot. What issues do you need to consider and what precautions should you take to avoid rollover accidents while operating here?

Which is Safer?

Driving on a hill with an empty bucket.

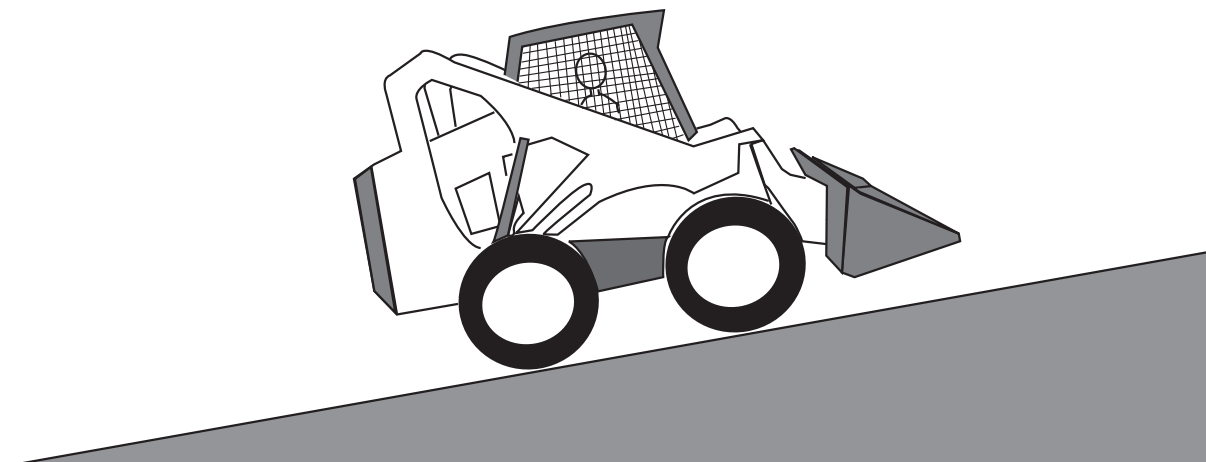
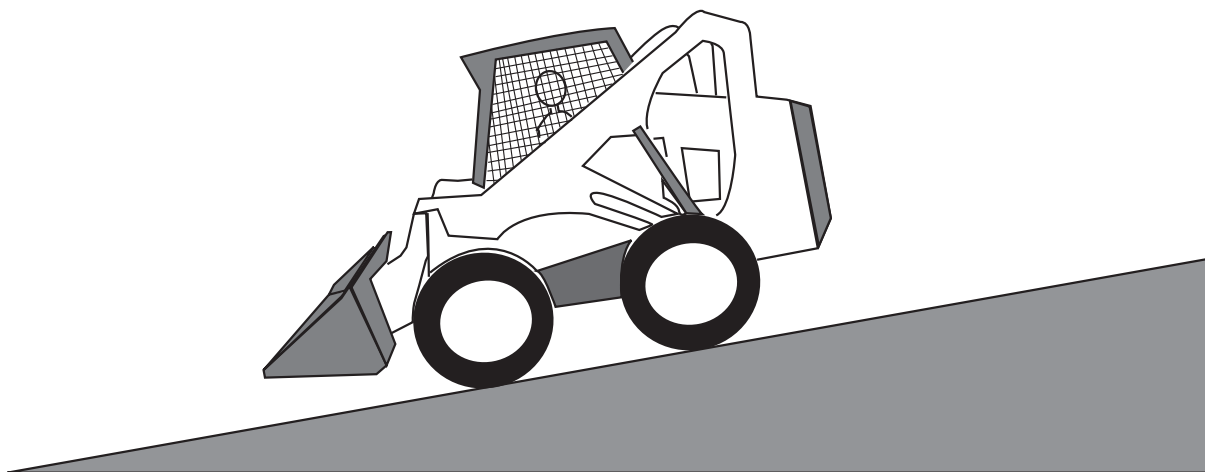

Which is Safer?

Driving on a hill with a heavy load in the bucket.

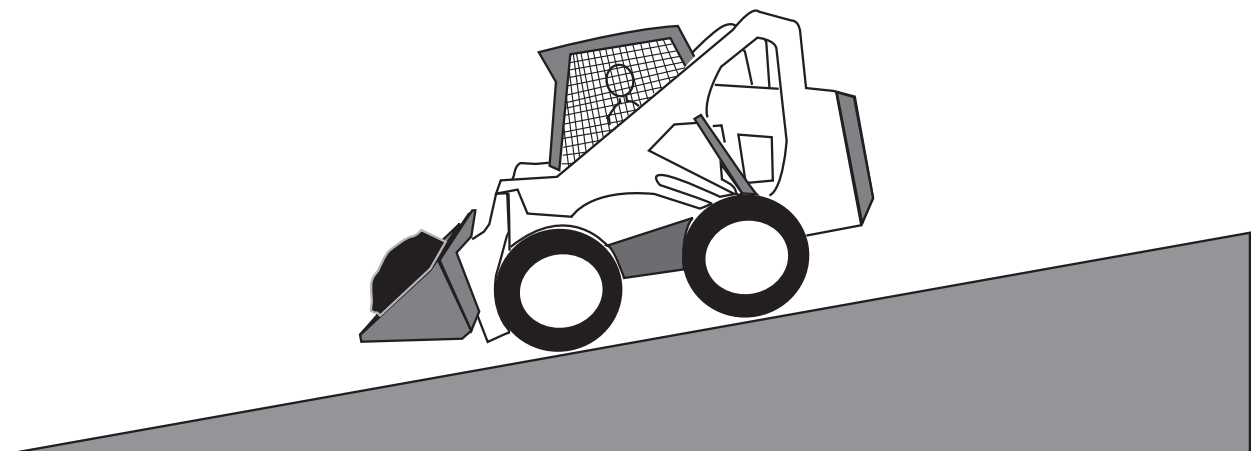
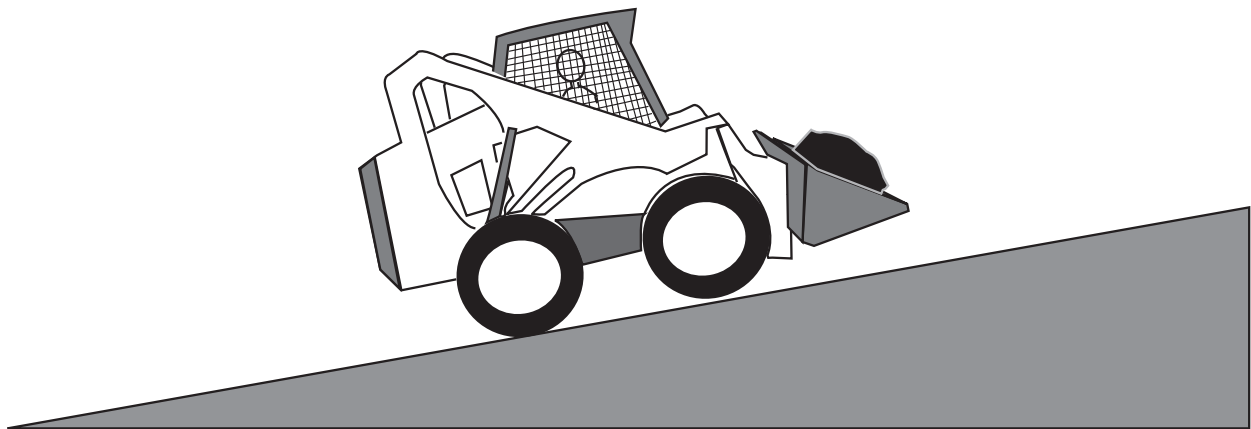

Which is Safer?

Driving forward with a heavy load in the bucket.

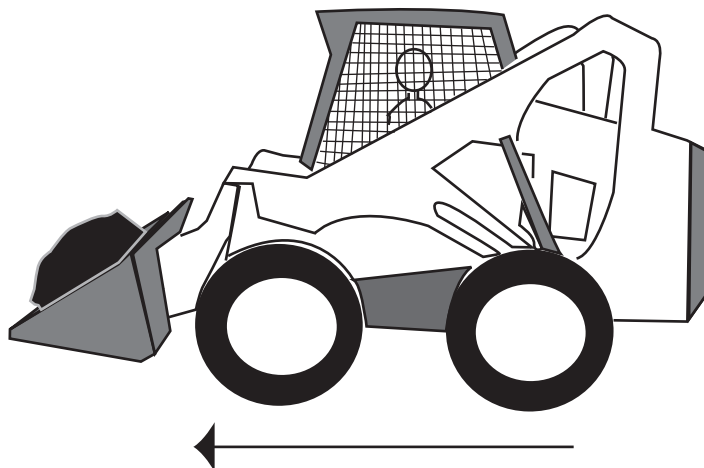
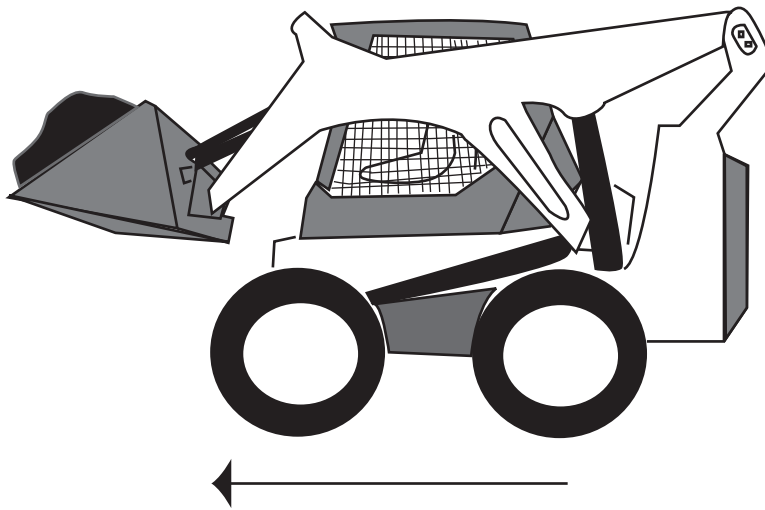

Which is Safer?

Driving on a hill.

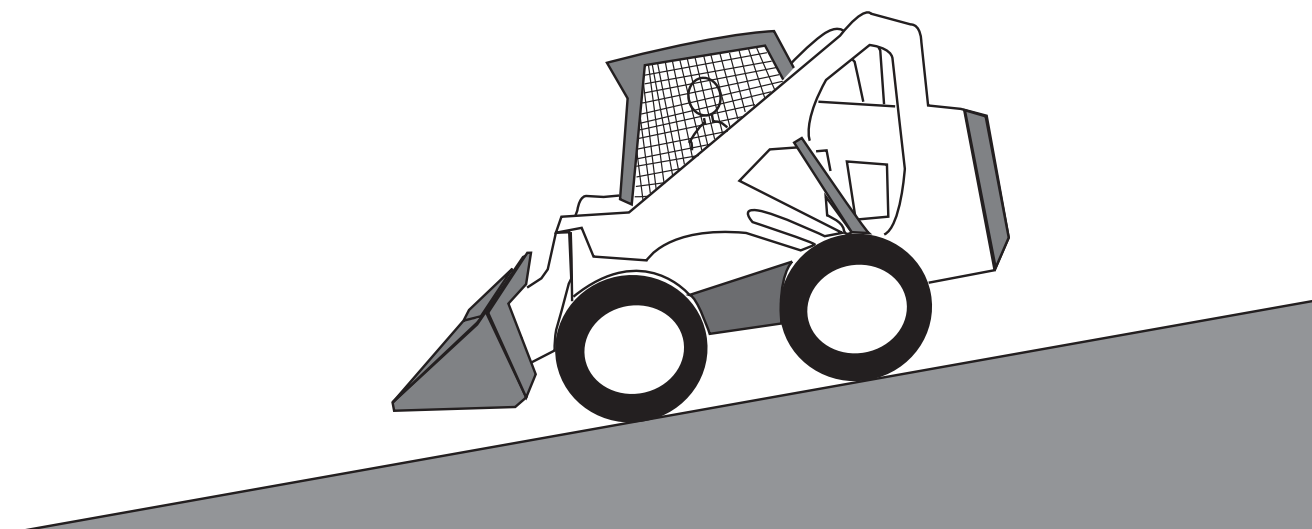
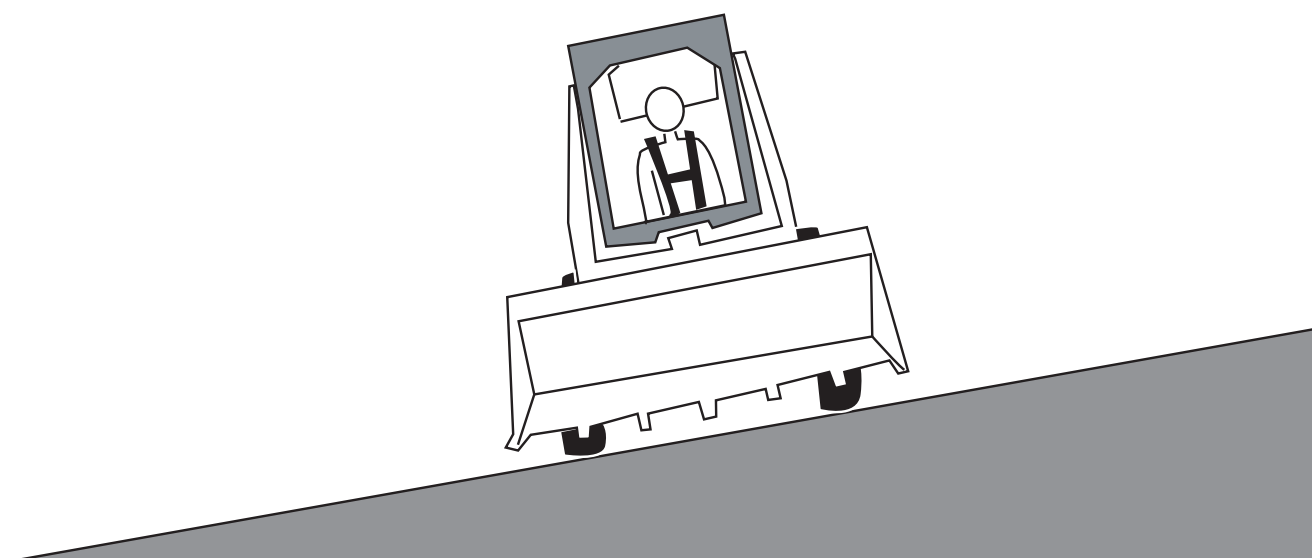

Which is Safer?

Driving with a large log in the bucket.

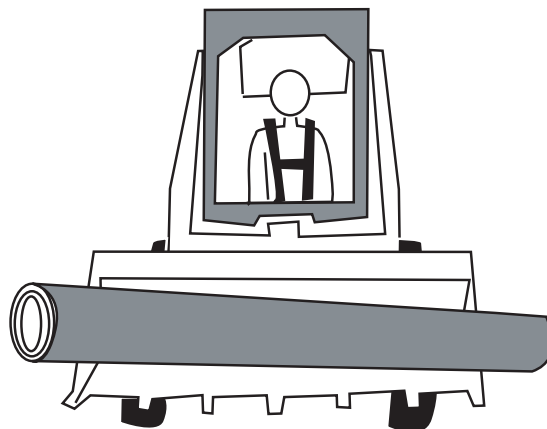
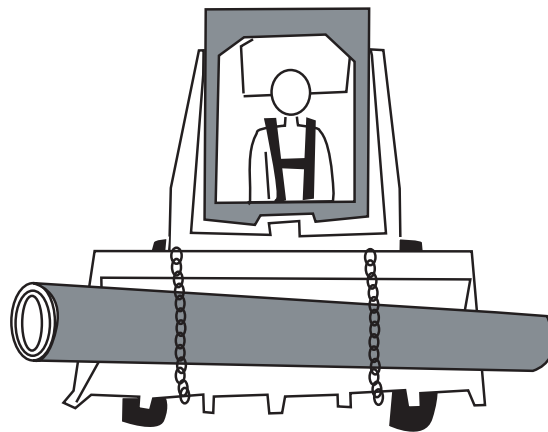

Which is Safer?

Carrying a heavy object.

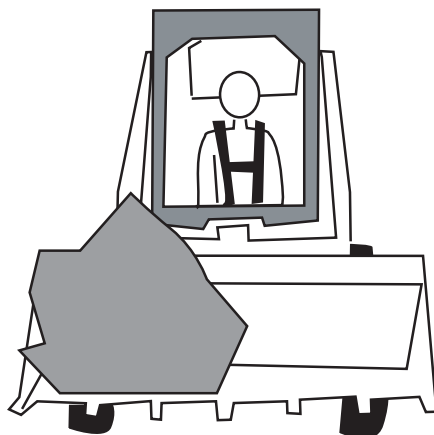
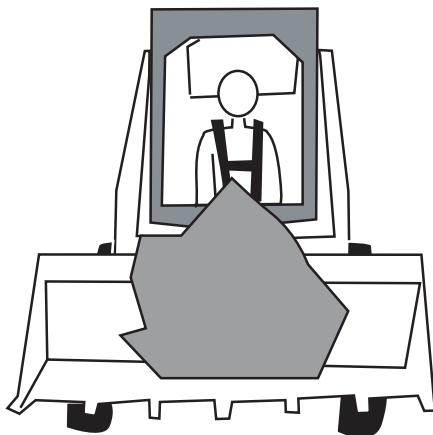

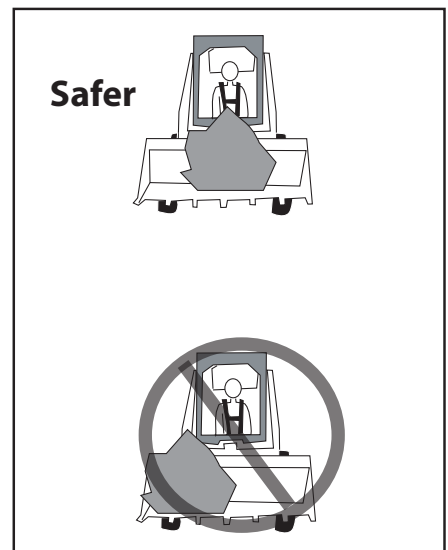
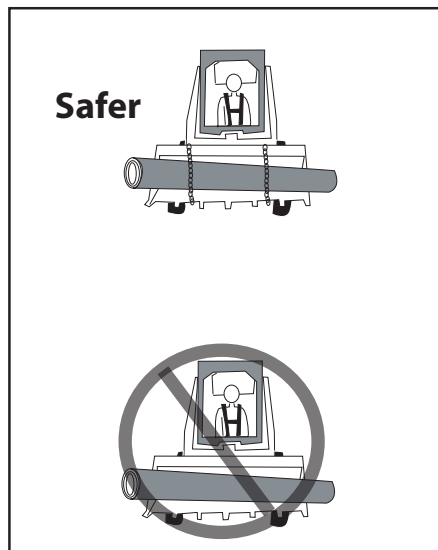
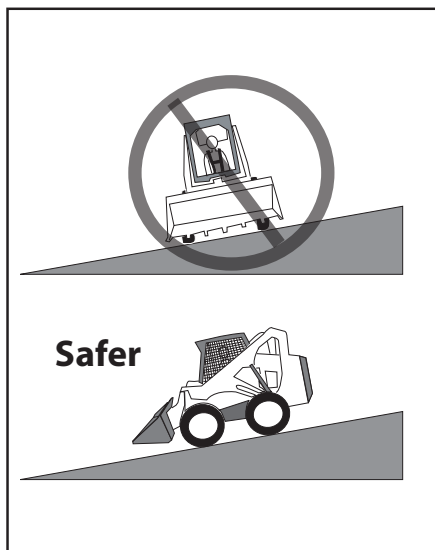
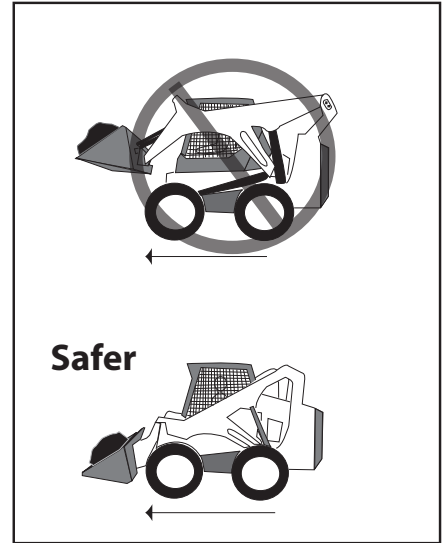
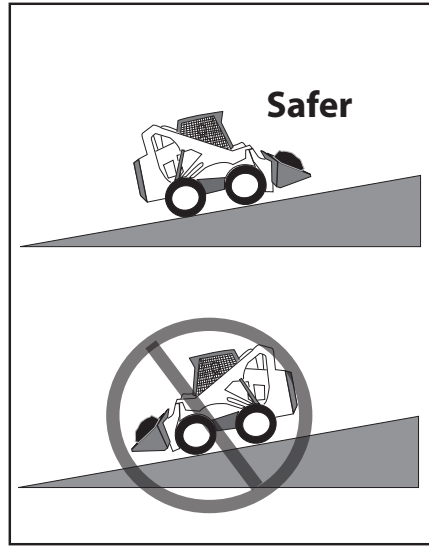
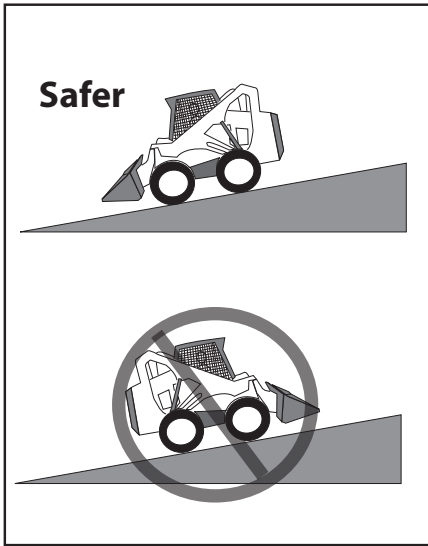

#1 Your crew will be working in large open area tomorrow (no shade). The weather is expected to be very hot and humid. One of your crew members is new, and it will be his first day on the job. What issues do you need to consider and what precautions should you take to protect the crew from heat illness?

#2 You and another worker have been working all day. The weather is hot and sunny. You notice your coworker doesn't look good. His skin is pale and sweaty and he says he feels sick to his stomach.

a) What actions do you take?

b) Despite your efforts, your coworker gets worse and begins acting disoriented. His face is flushed, and his skin feels hot and dry. Now what actions do you take?

c) What could have been done to prevent this from happening?

#3 You are clearing trees and brush along a powerline in a rural area. There is a severe thunderstorm watch in effect, and the sky looks stormy and dark. You think you see a flash of lightning far off on the horizon. You listen for thunder, but you don't hear anything other than the wind.

a) What actions do you take?

b) Suddenly lightning begins to flash around you. You have a work truck and trailer and there is an open metal shed nearby. Now what actions do you take?

1. Which of the following shows safety messages in order from most serious to least serious?

- a. Danger; Warning; Caution**
- b. Warning; Danger; Caution**
- c. Caution; Danger; Warning**

2. Never enter a skid steer loader unless:

- a. the lift arms are down and attachments are on the ground.**
- b. the engine is off.**
- c. both A and B.**

3. Never operate a skid steer loader unless:

- a. the safety belt is fastened.**
- b. the restraining bar is lowered (if so equipped).**
- c. both A and B.**

- 4. Do not get any part of your body beneath the raised lift arms and attachments unless they are supported by:**
- a. a concrete block.**
 - b. an approved support device.**
 - c. a jack.**
- 5. Which is the best practice for starting a skid steer loader?**
- a. If the starter isn't working, start the loader by shorting across the starter terminals.**
 - b. Never start loader from outside the cab.**
 - c. If the loader was shut down with the lift arms and attachment raised, re-start the loader by standing outside the cab and reaching in to turn the key.**

- 6. Which is the best practice for shutting down a skid steer loader?**
- a. Block the wheels if there is a chance the loader will roll.**
 - b. Leave the lift arms and attachment raised about a foot above the ground.**
 - c. Leave the engine running if you will be out of the cab less than 60 seconds.**
- 7. Which of the following is the best practice for avoiding heat illness?**
- a. Drink plenty of soda, tea or coffee.**
 - b. Drink at least a quart of water per hour.**
 - c. Eat large meals before working.**

- 8. Which is the best practice if you are in a skid steer loader and a coworker approaches to talk with you:**
- a. Ask him to lean into the cab so you can hear him above the engine noise.**
 - b. Tell him to stay back. Then lean out of the cab so you can hear him above the engine noise.**
 - c. Keep the coworker away until you lower the lift arms and attachments, shut off the engine and set the parking brake.**
- 9. Which of the following will help you avoid a rollover accident?**
- a. Keep the load high while you turn on hills.**
 - b. Carry loads close to the ground, but high enough to clear obstacles.**
 - c. Operate the lift controls as rapidly as possible.**

10. Which is the best practice when lifting a load?

- a. Check the data plate for lifting capacity.**
- b. Position a worker under the load to give hand signals to the operator.**
- c. Once the load is in the air, swing it rapidly into position.**

11. Which is the best practice if you have to operate on a hill or ramp?

- a. Drive across hills, not up and down.**
- b. Keep the heavy end of the loader uphill.**
- c. Keep the heavy end of the loader downhill.**

12. Which is the best practice to avoid running over coworkers?

- a. If a load blocks your view, either drive in reverse (if the loader is designed so you can see behind) or have a coworker guide you from a safe distance.**
- b. Drive past blind corners as quickly as possible.**
- c. Allow riders only if they hold firmly to the loader.**

13. Which is the best practice for digging into piles of materials?

- a. Never work with materials that are piled higher than your raised attachment.**
- b. When working with a tall pile of material, always dig into the bottom of the pile.**
- c. Ram the attachment into the pile with as much force as possible.**

14. Which of the following is the best practice when driving a loader onto a trailer?

- a. If the loader bucket is empty, drive up the ramp in reverse.**
- b. If the loader bucket is empty, drive forward up the ramp.**
- c. Ask a coworker to stand on the trailer and guide you as you drive up the ramp.**

15. Seek medical attention if:

- a. direct pressure will not stop a cut from bleeding.**
- b. burns occur on the face or genitals.**
- c. all of the above.**

Answer Key

Skid Steer Loader Safety Conclusion

1. a

2. c

3. c

4. b

5. b

6. a

7. b

8. c

9. b

10. a

11. b

12. a

13. a

14. a

15. c

Tree Trimming Training Guide

Suggested Materials

- Tree Trimming Safety* (English, MF2712; Spanish, MF2712S)
- Sign-in sheet
- Pencils
- Instructor Guide
- Training overheads/slides/projector
- Blank overheads/flipchart/blackboard/pen for listing participant responses and outlining important concepts
- Chipper/shredder and tractor for hands-on exercises
- Ear plugs and any other protective equipment for hands-on exercise
- First-aid kits for hands-on exercises
- Rope for practicing knots
- Tree climbing equipment for hands-on exercises
- Tree trimming equipment for hands-on exercises (chain saws, pole saws, ladders, aerial lifts, etc.)

Sources of Background Information

Tree trimming and aerial lift safety manuals available for download:

http://www.ksre.ksu.edu/library/landscaping_equipment_safety.htm

Operator's manuals for chainsaws (available from dealer)

Arborists Certification Study Guide, International Society of Arboriculture.

www.isa-arbor.com

Tree Climber's Guide, International Society of Arboriculture.

www.isa-arbor.com

National Tree Climbing Guide, United States Department of Agriculture's National

Tree Climbing Program. www.fs.fed.us/treeclimbing/

OSHA Logging Web page, <http://www.osha.gov/SLTC/logging/index.html>

OSHA Logging e-Tool, <http://www.osha.gov/SLTC/etools/logging/mainpage.html>

NIOSH Logging Web page, <http://www.cdc.gov/niosh/injury/traumalog.html>

Length of Time Needed for Training

Review and select the learning activities that are most appropriate. If all of the discussion and hands-on exercises are included in the training it may take up to a full work day. Without the hands-on exercises, the classroom portion will take about two hours.

Welcome and Introduction

- ▶ Introduce yourself.
- ▶ Remind participants of the topic of the training.
- ▶ Discuss exit locations, emergency procedures, breaks, locations of restrooms, ending time and any tests or evaluations.
- ▶ Tell participants you expect them to play an active role by relating their experiences and knowledge.

Participant Introductions

Find out:

- ▶ Who are they?
- ▶ What is their experience trimming and felling trees?
- ▶ What do they hope to learn from the training?

Questioning/Disucssion

Before beginning Lesson 1:

- ▶ What do participants think are the most common types of accidents that happen when trimming and feeling trees. List ideas on an overhead or flipchart.
- ▶ Have any participants known someone who has been killed or seriously injured in a tree trimming accident? Would anyone care to share what happened?

Take Control of Your Own Safety

Lesson 1

Suggested Objectives

- Name the most common types of tree trimming accidents.
- Interpret the meaning of common warning signs and labels.
- Identify appropriate protective equipment.
- Indicate hazards to be assessed before beginning operation.

Discuss Accident Reports on page 4 of *Tree Trimming Safety*.

- ▶ How well did participants' ideas for the most common causes of accidents match those in the tree trimming safety manual? (Refer to the overhead or flipchart list made during the introduction.)
- ▶ Are participants surprised by any of the most common types of accidents?

Hands-on Exercise

Divide the class into groups of three to five participants. Have each group look for safety messages and signs on some of the equipment they commonly use (chain saws, pole saws, ladders, aerial lifts, etc.). Bring the class together and ask each group to report on the hazards described in the messages and signs.

Hands-on Exercise

Have participants inspect and wear any protective equipment that is required for their work. Discuss the importance of each item.

Try on hearing protection:

- ▶ follow manufacturer's procedure or use the general procedure on the following page.
- ▶ demonstrate technique.
- ▶ provide feedback as participants practice.

Types of Hearing Protection:



Inserting Ear Plugs

Ear Plugs



- ▶ Clean hands.
- ▶ Roll ear plug between fingers to compress it.
- ▶ Grasp ear from behind your head with opposite hand and pull up to straighten ear canal.
- ▶ Insert ear plug until it blocks sound, then hold in place while it expands. (Count out loud to 20 while it expands.)
- ▶ Ear plug must completely fill ear canal.
- ▶ Test fit by cupping hands over ears and then releasing. There should not be much difference in sound.
- ▶ Wash reusable plugs in warm soapy water after use/throw away disposable after each use.

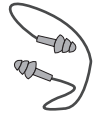

Hearing Bands



- ▶ Grasp ear from behind your head with opposite hand and pull up to straighten ear canal.
- ▶ Use your hands to press the ear pads into the ear canals.
- ▶ Test fit in a noisy environment: Lightly press band inward and you should not notice much reduction in noise level.

Ear Muffs



- ▶ Make sure the cushions fully cover the ear and seal tightly against the head.
- ▶ Hold the headband at the crown of the head and adjust each cup.
- ▶ Test fit in a noisy environment: Gently push the cups toward your head and release. There should not be much difference in noise level.

Hands-on Exercise

Divide the class into groups of three to five participants. Have each group evaluate equipment and a work area, including trees to be trimmed and felled using the Pre-Operation Inspection on page 169 of the Instructor Guide. Bring the class back together and have each group report regarding hazards they observed and precautions that need to be taken.

Evaluation

Answer the quiz items on page 9 of *Tree Trimming Safety* individually or as a class. Be sure to discuss each item.

Questioning/Discussion

Before beginning Lesson 2:

- ▶ Ask participants if it is possible to get electrocuted from a power line if they don't actually touch the line. Ask participants to describe how this can happen. List ideas on an overhead or flipchart.
- ▶ Are participants aware that most power lines are not insulated?
- ▶ Have participants known of anyone who has been electrocuted from a power line? Would they care to share what happened?

Avoid Shock and Electrocutation

Lesson 2

Suggested Objectives

- Differentiate between qualified and unqualified line-clearance tree trimmers.
- Recognize electrical hazards.
- Identify minimum distance requirements.

Discuss Accident Reports on pages 10-11 of *Tree Trimming Safety*.

- ▶ Discuss the ways that workers can be electrocuted without actually touching a power line. How well does this information match the list participants made at the end of Lesson 1? Are they surprised by any of the differences?
- ▶ Regarding work around power lines, what is the difference between qualified and unqualified employees? Have any of the participants had the additional training needed to become qualified?
- ▶ Discuss your organization's policy regarding work around power lines. What is the procedure for contacting the electric company when power lines need to be shut down or shielded?

Evaluation

Answer the quiz items on page 13 of *Tree Trimming Safety*.

Hands-on Exercise

As a group, go outside and evaluate electrical hazards involving nearby trees. For qualified and unqualified employees, what precautions need to be taken before trimming/felling specific trees?

Lesson 3

Preventing Falls from Trees

Suggested Objectives

- Recognize precautions to prevent falling from trees.
- Identify climbing knots.

Discuss Accident Report on page 14 of *Tree Trimming Safety*.

- ▶ Ask participants to read key points under “Avoid Injury from Falling” on page 14 of *Tree Trimming Safety*. What are some reasons other workers might not observe some of these rules? Why are the rules important?

Hands-on Exercises

- ▶ Demonstrate and have participants practice tying knots that are useful for climbing trees.
- ▶ Demonstrate and have participants practice tree climbing techniques, using appropriate equipment. Participants must be at least 18 years of age, properly supervised, equipped and dressed, and in acceptable health. The climbing location must be safe, and the climbing tasks must be appropriate for participants’ skills and experience.

Contest

Break the class into small groups. Select several knots that are useful for climbing. For each knot, allow an appropriate amount of time for participants to tie the knot. Group members may coach each other and use the tree trimming safety manual as a guide, but each participant must tie each knot. Check the knots and award points to each group for the number of knots they were able to tie correctly in the allotted time.

Evaluation

Answer the quiz items on page 17 of *Tree Trimming Safety*.

Avoid Being Struck by Trees or Limbs

Lesson 4

Suggested Objectives

- Recognize ways to avoid being struck by trees and limbs.
- Develop safe chainsaw operating procedures.
- Identify tree felling danger zones.
- Compare different felling techniques.

Discuss Accident Reports on pages 18-22 of *Tree Trimming Safety*.

- ▶ Have participants known of workers getting seriously hurt in any other ways while trimming or felling trees?

Contest

Divide the class into groups. Display the contest items provided on pages 156-161 of the Instructor Guide. In turn, ask each group a multiple choice or true/false question from the overheads. Each group gets one point for every correct answer. If a group misses a question, allow the next group to answer it for a point. Keep track of points and recognize the winning group. Use the questions as opportunities to discuss the training material. Answer key provided on page 162 of the Instructor Guide.

Discussion

Discuss the open face and Humboldt notches on page 24 of *Tree Trimming Safety*. Participants may not be familiar with the open face notch. However, it allows for greater felling accuracy and less danger of kickback than the other two notches. Additional felling techniques for difficult trees can be found in OSHA's Logging e-Tool at: <http://www.osha.gov/SLTC/etools/logging/mainpage.html>.

Hands-on Exercises

Perform the following exercises in a safe location away from power lines and other hazards. Observe all necessary precautions, and keep participants a safe distance from falling limbs and trees.

- ▶ Evaluate trees to be trimmed or felled. Discuss trimming and felling techniques that are appropriate for specific trees and limbs.
- ▶ Set up a safe work area and practice making cuts, using appropriate equipment.
- ▶ Practice cutting with chainsaws. Include proper techniques for inspection, fueling, starting, operating and shutting down safely.

Evaluation

Answer the quiz items on page 25 of *Tree Trimming Safety*. Be sure to discuss each item.

Lesson 5

Environmental Hazards

Suggested Objectives

- Identify environmental hazards.
- Recognize treatment and first aid for exposure to environmental hazards.

Discuss Accident Report on page 26 of *tTree Trimming Safety*.

- ▶ What precautions do participants already take to protect themselves from heat and sun exposure while working? List participant responses on an overhead or flipchart.
- ▶ Does this list include all of the most important precautions?

Problem Solving

Discuss the overhead on page 163 of the Instructor Guide. Make sure participants know that more cases of skin cancer are diagnosed each year than breast, lung, prostate, colorectal and kidney cancers combined. Ask participants if they are taking adequate precautions.

Visual Aid

Discuss the overhead “Is This a Good Idea?” on page 165 of the Instructor Guide. Ask participants to identify all of the safety problems in the story. Then discuss how the worker might have handled the situation in a better manner.

Discussion

- ▶ What job tasks expose participants to frigid winter weather? During these jobs, what parts of their body are most affected by the cold? In their experience, what are the most effective ways to prevent hypothermia and frostbite on the job?
- ▶ Have any participants ever had problems with insects, animals or poisonous plants while trimming or felling trees? Would they care to share what happened? What precautions can they take?

Hands-on Exercise

Using the company’s first aid kits, demonstrate and have participants practice first aid for cuts, burns, heat exhaustion, cold injury and lightning strike.

Evaluation

Answer the quiz items on page 32 of *Tree Trimming Safety* either individually or as a class. Be sure to discuss each item.

Conclusion

Case Studies

Break the class into small groups of three to five participants. Provide each group with one of the scenarios on pages 166-168 of this Instructor Guide. Ask each group to discuss their scenario. If there are more than three groups, more than one group can work on the same scenario. Monitor the progress of each group. Bring the class back together and ask for a representative from each group to read their problem and explain their solution. Display case study overheads as each group takes turns. Ask other groups what they think of the proposed solution.

Discussion

Ask participants to share any questions or concerns they may still have or want to discuss further.

Evaluation

Answer the quiz questions on page 34-35 of *Tree Trimming Safety* either individually or as a group. Be sure to discuss each item.

Hands-on Performance Evaluation

In a safe area with adequate supervision, have each participant complete a hands-on performance evaluation. The evaluation may include:

- ✓ Completing Pre-Operation Inspection provided on page 169 of the Instructor Guide
- ✓ Selecting and using appropriate equipment
- ✓ Following power line precautions
- ✓ Using proper trimming and felling procedures

A checklist for the performance evaluation is provided on page 170 of the Instructor Guide.

1. On a level surface, no one (other than the feller) should be within ____ tree lengths of the tree being felled.

- a. two**
- b. three**
- c. four**

2. Never operate a chain saw above your:

- a. knees.**
- b. belt.**
- c. chest.**

3. To refuel a chain saw, shut down the engine and wait at least _____ minute(s) for the engine to cool.

- a. 1**
- b. 3**
- c. 5**

4. How many cuts are normally required to prune a large branch from a tree safely and without damaging the bark?

- a. 1**
- b. 2**
- c. 3**

5. To reduce kickback:

- a. insert the saw blade fully.**
- b. insert the saw blade about half way.**
- c. cut with the tip of the saw blade.**

6. Kickback can occur when:

- a. the tip of the saw contacts a hard object.**
- b. the teeth of the saw blade are pinched in the wood.**
- c. both A and B.**

- 7. Which of the following is the safest practice when trimming trees?**
- a. If branches cannot be dropped safely, cut them and leave them in the tree.**
 - b. Never turn your back on a tree where branches are being cut or when a tree is being felled.**
 - c. Workers on the ground should try to catch branches as they fall.**
- 8. When felling a tree on level ground, everyone other than the feller should stay at least two tree lengths away. If the tree is going to fall downhill, this distance should be:**
- a. decreased.**
 - b. increased.**
 - c. unchanged.**

- 9. When a tree is being felled, the direction of the fall will be affected by:**
- a. wind and any vines or branches that are interlocked with other trees.**
 - b. any pre-existing damage or leaning of the trunk.**
 - c. both A and B.**
- 10. When felling a tree, you first cut a notch in the trunk in the direction you want the tree to fall. This notch is called the:**
- a. back cut.**
 - b. scarf.**
 - c. hinge.**
- 11. When felling a tree, the final cut is called the:**
- a. back cut.**
 - b. scarf.**
 - c. hinge.**

- 12. When felling a tree, the hinge wood is left between the back cut and scarf. Normally, the hinge wood should be equal to _____ the tree's diameter.**
- a. 1/10th**
 - b. 1/5th**
 - c. 1/3rd**
- 13. When felling a tree, the best escape areas are located:**
- a. on the side of the tree where you make the back cut.**
 - b. on the side of the tree where you make the scarf.**
 - c. neither A nor B.**

- 14. For the conventional notch, the scarf should normally penetrate the tree to a distance of about:**
- a. $1/5$ to $1/4$ of the tree's diameter.**
 - b. $1/4$ to $1/3$ of the tree's diameter.**
 - c. $1/3$ to $1/2$ of the tree's diameter.**
- 15. For the conventional notch, the back cut should normally start about _____ above the bottom cut.**
- a. 1 inch**
 - b. 6 inches**
 - c. 1 foot**

1. a

2. c

3. c

4. c

5. a

6. c

7. b

8. b

9. c

10. b

11. a

12. a

13. c

14. b

15. a

According to the American Cancer Society, what is the most common form of cancer?

- a. Lung
- b. Skin
- c. Breast
- c. Prostate

According to the American Cancer Society, what is the most common form of cancer?

a. Lung

b. Skin

c. Breast

c. Prostate

Is This a Good Idea?

A worker was trimming trees near a power line on a rural highway. Storm clouds were on the horizon. He could see far-off lightning flashes. He could also hear distant thunder. He thought, “I’ll keep working until the lightning gets closer.” Just then, a bolt of lightning struck a nearby utility pole. The startled worker ran and took cover under a large tree.

#1 You are in charge of a three-person crew that will be trimming and felling storm-damaged trees in a hilly residential area. Based on the equipment you normally have available, describe in detail the precautions you will take to protect your workers and residents from falling limbs and trees while you work.

#2 You are in charge of a crew that will be trimming limbs near a power line. Two of your workers are qualified to work near power lines and one is not. Based on the equipment you normally have available, describe in detail how you will plan and carry out the work to keep all workers safe from electrocution.

#3 You are in charge of a crew that will be trimming and felling ice-damaged trees. Based on the equipment you normally have available, describe in detail the precautions you will take to ensure none of your crew will fall from trees, ladders or equipment while you work.

Daily Pre-Operation Inspection: Tree Trimming

Operator: _____ Date: _____

Item	OK	Needs Attention	Specific Comments
Tree <ul style="list-style-type: none"> ● Trunk free of cracks, splits or cankers. ● No nests, hives or other signs of animal life. ● No signs of poison ivy or oak. 			
Equipment <ul style="list-style-type: none"> ● Belts and harnesses free of cracks, cuts and broken stitching. ● Clips, buckles and rivets not loose or broken. ● Ropes and lanyards are dry and show no signs of fraying, intense wear or sun damage. ● Snap catches and carbiners close securely and are the appropriate size for the D-rings in use. ● Other personal protective equipment used as needed, such as hearing and eye protection. 			
Location <ul style="list-style-type: none"> ● Warning signs and rumble strips are being used when site is near a roadway. ● Cones and flaggers are used to divert traffic. 			

Operator Performance Evaluation: Tree Trimming

Operator: _____ Date: _____

Instructor: _____ Location: _____

	Satisfactory	Needs Improvement
Follows Pre-Operation Inspection		
Safe Start Up		
● Clear the area of bystanders.		
● Wear personal protective equipment, including hearing and eye protection, as necessary.		
● Dress appropriately.		
● Follow powerline precautions.		
Safe Operation		
● Doesn't endanger people or property.		
● Operates equipment according to manufacturer's instructions.		
● Follows two tree rule when felling.		
● Does not turn back on tree where others are working.		
● Safely climbs trees, if necessary.		
● Use appropriate cuts for trimming and felling.		
● Avoid danger zone when felling.		

Aerial Lift Safety Training Guide

Suggested Materials

- Aerial Lift Safety* (English, MF2713; Spanish, MF2713S)
- Sign-in sheet
- Pencils
- Instructor Guide
- Training overheads/slides/projector
- Blank overheads/flipchart/blackboard/pen for listing participant responses and outlining important concepts.
- Ear plugs and other appropriate protective equipment for hands-on exercises
- Fall protection equipment (lanyard, harnesses, etc.)
- First aid kits for hands-on exercises
- Aerial lift truck for hands-on exercises
- Temporary traffic control devices for hands-on exercises
- Other equipment appropriate for hands-on exercises (chainsaws, pole saws, etc.)

Sources of Background Information

Aerial lift and tree trimming safety manuals available for download:

http://www.ksre.ksu.edu/library/landscaping_equipment_safety.htm

Operator's manuals for aerial lifts (available from dealer)

Length of Time Needed for Training

Review and select the learning activities that are most appropriate. If all the discussion and hands-on exercises are included in the training it may take up to a full work day. Without the hands-on exercises, the classroom portion will take about two hours.

Welcome and Introduction

- ▶ Introduce yourself.
- ▶ Remind participants of the topic of the training.
- ▶ Discuss exit locations, emergency procedures, breaks, locations of restrooms, ending time and any tests or evaluations.
- ▶ Tell participants you expect them to play an active role by relating their experiences and knowledge.

Participant Introductions

Find out:

- ▶ Who are they?
- ▶ What is their experience with aerial lifts?
- ▶ What do they hope to learn from the training?

Questioning/Discussion

Before beginning Lesson 1:

- ▶ What do participants think are the most common types of accidents that involve aerial lifts? List ideas on an overhead or flipchart.
- ▶ Have any participants known someone who has been killed or seriously injured in an aerial lift accident? Would anyone care to share what happened?

Lesson 1

Take Control of Your Own Safety

Suggested Objectives

- Name the most common types of accidents involving aerial lift devices.
- Interpret the meaning of common warning signs and labels.
- Identify appropriate protective equipment.

Discuss Accident Reports on pages 4-5 of *Aerial Lift Safety*.

- ▶ Refer to the list of participants' ideas about the most common causes of accidents. How well do participant's ideas match the actual causes of death?
- ▶ Are participants surprised by any of the most common types of accidents?

Hands-on Exercise

- ▶ Divide the class into groups of three to five participants. Have each group look for safety messages and signs on equipment they commonly use (aerial lifts, chain saws, pole saws, etc.). Bring the class together and ask each group to report on the hazards described in the messages and signs they saw.
- ▶ Have participants inspect and wear any protective equipment that is required for their work. Discuss the importance of each item.
- ▶ Practice wearing hearing protection:
 - ▶ Follow manufacturer's procedure or use the general procedure on the next page.
 - ▶ Demonstrate technique.
 - ▶ Provide feedback as participants practice.



Inserting Ear Plugs

Types of Hearing Protection:

Ear Plugs

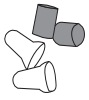

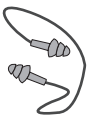
- ▶ Clean hands.
 - ▶ Roll ear plug between fingers to compress it.
 - ▶ Grasp ear from behind your head with opposite hand and pull up to straighten ear canal.
 - ▶ Insert ear plug until it blocks sound, then hold in place while it expands. (Count out loud to 20 while it expands.)
 - ▶ Ear plug must completely fill ear canal.
- 
- ▶ Test fit by cupping hands over ears and then releasing. There should not be much difference in sound.
 - ▶ Wash reusable plugs in warm soapy water after use/throw away disposable after each use.

Hearing Bands



- ▶ Grasp ear from behind your head with opposite hand and pull up to straighten ear canal.
- ▶ Use your hands to press the ear pads into the ear canals.
- ▶ Test fit in a noisy environment: Lightly press band inward and you should not notice much reduction in noise level.

Ear Muffs



- ▶ Make sure the cushions fully cover the ear and seal tightly against the head.
- ▶ Hold the headband at the crown of the head and adjust each cup.
- ▶ Test fit in a noisy environment: Gently push the cups toward your head and release. There should not be much difference in noise level.

Evaluation

Answer the quiz items on page 8 of *Aerial Lift Safety* individually or as a class. Be sure to discuss each item.

Questioning/Discussion

Before beginning Lesson 2:

- ▶ What specific safety items do participants check in regard to their equipment and worksite before beginning each job? List responses on an overhead or flipchart.
- ▶ What precautions do they take when they shut down their equipment and leave it unattended?

Lesson 2

Prepare for Safe Operation

Suggested Objectives

- Indicate parts to be inspected before operation.
- Recognize safe start up, shut down and operating procedures.
- Identify guidelines for working near traffic.

Discuss the Pre-Start Inspection and Checklist on pages 9-10 of *Aerial Lift Safety*.

- ▶ How do the checklist items compare with the list made by participants at the end of Lesson 1.
- ▶ Discuss your company's policy for recording pre-operation equipment checks.
- ▶ Discuss the safety features that are present on your company's aerial lift trucks. Why are these important?
- ▶ Discuss your company's policy for safety belt use.
- ▶ Discuss your company's practices for communication between the person on the lift and those on the ground.

Analysis

On pages 10-11 of *Aerial Lift Safety*, have each participant read one of the following items and briefly give an example of how an accident could occur if the procedure isn't observed.

- ▶ Items 1, 2, 3, 4, 5, and 6 under "Start Up Safety Procedures"
- ▶ Items 1, 2, 3, 4, 6, and 7 of "Safe Shut Down Procedures"
- ▶ All bullets under "General Operating Procedures"

Visual Aid

Display and discuss the overhead/slide entitled, "Is This a Good Idea?" on page 181 of the Instructor Guide.

- ▶ Ask participants to identify all safety problems indicated in the story.
- ▶ Discuss how the worker could have handled the situation in a better manner.

Discuss any points from "Maintenance Precautions" and "Driving in Traffic" that haven't been mentioned.

Discussion

What is the company's policy for ventilating the repair shop while working on equipment with the engine running?

Hands-on Exercises

- ▶ Ask participants to inspect an aerial lift using a checklist such as the Pre-Start Checklist on page 10 of *Aerial Lift Safety* or the Pre-Operation Inspection provided on page 199 of the Instructor Guide. After the inspection, ask participants to identify crush points and discuss appropriate precautions.
- ▶ With the class observing, ask a participant to demonstrate how to safely fuel an aerial lift. Why is it important to touch the fuel nozzle to the lift before opening the fuel cap?
- ▶ Have the class set up an aerial lift for operation in safe area. Individually, have participants start the aerial lift, operate the basic controls, and shut it down. Before beginning, instruct participants about the operating controls and keep everyone out of the way. Discuss any procedures that may be relevant for other types of aerial lifts. Practice attaching and operating any attachments employees will be expected to use.
- ▶ In a safe area such as a private road or parking lot on your company's property, have participants set up a roadside work area using traffic cones and flaggers, as appropriate. Make sure all participants wear brightly-colored reflective vests and any other safety equipment that your organization requires for this type of work. Guidelines for roadside work areas are detailed in *Motor Vehicle Safety Manual for the Landscaping and Horticultural Services Industry*:
http://www.ksre.ksu.edu/library/landscaping_equipment_safety.htm

Evaluation

Answer the quiz items on page 13 of *Aerial Lift Safety*, either individually or as a class. Be sure to discuss each item.

Lesson 3

Prevent Lift Overturns

Suggested Objectives

- Identify safe operating procedures to prevent a lift overturn.

Discuss the Accident Reports on pages 14-15 of *Aerial Lift Safety*.

Case Studies

Break the class into small groups of three to five participants. Provide each group with one of the scenarios on pages 182-184 of this Instructor Guide. Ask each group to discuss their scenario, using the information from Lesson 3 of *Aerial Lift Safety*. If there are more than three groups, more than one group can work on the same scenario. Monitor the progress of each group. Bring the class back together and ask for a representative from each group to read their problem and explain their solution. Display case study overheads as each group takes turns. Ask other groups what they think of the proposed solution.

Hands-on Exercise

Break the class into groups of three to five participants. Identify several distinct tree-trimming areas nearby. Have each group evaluate a work area for hazards that could result in an overturn. Bring the class back together and have each group report about the hazards they observed and precautions that need to be taken.

Evaluation

Answer the quiz items on page 16 of *Aerial Lift Safety*, either individually or as a class. Be sure to discuss each item.

Prevent Falls from Aerial Lifts

Lesson 4

Suggested Objectives

- Identify steps to secure yourself in the bucket of the lift.
- Recognize safe operating procedures to avoid falling from an aerial lift.
- Indicate how to avoid being struck by objects that fall from the lift.

Discuss the Accident Reports on pages 17-18 of *Aerial Lift Safety*.

Case Studies

Break the class into small groups of three to five participants. Provide each group with one of the scenarios on pages 185-187 of this Instructor Guide. Ask each group to discuss their scenario, using the information from Lesson 4 of *Aerial Lift Safety*. If there are more than three groups, more than one group can work on the same scenario. Monitor the progress of each group. Bring the class back together and ask for a representative from each group to read their problem and explain their solution. Display case study overheads as each group takes turns. Ask other groups what they think of the proposed solution.

Hands-on Exercise

- ▶ Have participants perform an inspection of a lanyard, harness and any other fall protection equipment they will be using.
- ▶ Demonstrate and ask participants to practice securing themselves in the lift bucket with the fall protection equipment they will be using.

Evaluation

Answer the quiz items on page 19 of *Aerial Lift Safety*, either individually or as a class. Be sure to discuss each item.

Question/Discussion

Before beginning Lesson 5:

- ▶ Ask participants if it is possible to get electrocuted by a power line if they don't actually touch the line. What are some ways this can happen? List responses on an overhead or flipchart.
- ▶ Are participants aware that most power lines are not insulated?
- ▶ Have participants known of anyone who has been electrocuted from a power line? Would they care to share what happened?

Lesson 5

Avoid Contact With Power Lines

Suggested Objectives

- Differentiate between qualified and unqualified line-clearance tree trimmers.
- Recognize electrical hazards.
- Identify safe working distances from power lines.

Discuss the Accident Reports on pages 20-21 of *Aerial Lift Safety*.

- ▶ Discuss how participants could be electrocuted without actually touching a power line. How well does this information match the list they made earlier? Are they surprised by any of the differences?
- ▶ Regarding work around power lines, what is the difference between qualified and unqualified employees? Have any of the participants had the additional training needed to become qualified?
- ▶ Discuss your company's policy regarding work around power lines. What is the procedure for contacting the electric company when power lines need to be shut down or shielded?
- ▶ Discuss what participants would do if their aerial lift came in contact with a power line.
- ▶ Discuss your company's policy regarding workers on the ground when a lift is being used to trim trees near power lines.
- ▶ Discuss insulation features and grounding requirements of the company's lift trucks. What are the limitations of these features? What are the operator's responsibilities for checking these features before each job?

Hands-on Exercise

- ▶ As a group, go outside and evaluate hazards involving nearby trees. For qualified and unqualified employees, what precautions need to be taken before trimming specific trees?

Evaluation

Answer the quiz items on page 23 of *Aerial Lift Safety*, either individually or as a group. Be sure to discuss each item.

Environmental Hazards

Lesson 6

Suggested Objectives

- Identify environmental hazards.
- Recognize treatment and first aid for exposure to environmental hazards.

Case Studies

Break the class into small groups of three to five participants. Provide each group with one of the scenarios on pages 188-190 of this Instructor Guide. Ask each group to discuss their scenario, using the information from Lesson 6 of *Aerial Lift Safety*. If there are more than three groups, more than one group can work on the same scenario. Monitor the progress of each group. Bring the class back together and ask for a representative from each group to read their problem and explain their solution. Display case study overheads as each group takes turns. Ask other groups what they think of the proposed solution.

Discuss

- ▶ When you are using an aerial lift in frigid winter weather, what body parts are most likely to be injured by the cold? Why?
- ▶ Ask participants what actions they have found most effective for preventing cold-induced injury.
- ▶ Have any participants ever had a bad experience with insects, animals, or poisonous plants while working at their jobs? Would they care to share what happened?

Hands-on Exercise

Using the company's first aid kits, demonstrate and have participants practice first aid for cuts, burns, heat exhaustion, cold injury and lightning strike.

Evaluation

Answer the quiz items on page 30 of *Aerial Lift Safety*, either individually or as a class. Be sure to discuss each item.

Conclusion

Contest

Divide the class into groups. Display the contest items provided on pages 191-197 of the Instructor Guide. In turn, ask each group a multiple choice or true/false question from the overheads. Each group gets one point for every correct answer. If a group misses a question, allow the next group to answer it for a point. Keep track of points and recognize the winning group. Use the questions as opportunities to discuss the training material. Answer key provided on page 198 of the Instructor Guide.

Discussion

Ask participants to share any questions or concerns they may still have or want to discuss further.

Evaluation

Answer the quiz questions on pages 32-33 of *Aerial Lift Safety*, either individually or as a group. Be sure to discuss each item.

Hands-on Performance Evaluation

In a safe area with adequate supervision, have each participant complete a hands-on performance evaluation while operating an aerial lift in small “work crews.”

The evaluation may include:

- ✓ Pre-Operation Inspection provided on page 199 of the Instructor Guide
- ✓ Determining if power line precautions are required
- ✓ Setting up the lift
- ✓ Manuevering
- ✓ Safe shut-down

A checklist for the performance evaluation is provided on page 200 of the Instructor Guide.

Is This a Good Idea?

A worker was getting an aerial lift truck ready for work. With the engine running, he raised the boom and then stood underneath it while he greased the lubrication points. He lowered the boom, used a bumper jack to raise the front of the truck, and crawled underneath to change the oil. When he finished, he tossed his tools in the bucket of the boom, hopped in the cab, and headed for the job site.

#1 You have been asked to use the boom of your aerial lift to pick up some logs and set them in the back of a dump truck. What issues do you need to consider? What precautions should you take to avoid an overturn?

#2 A few hours after a severe thunderstorm, your crew is sent to trim damaged trees in a residential area with an aerial lift. You have never been to this area before. In regard to rollovers, what hazards or problems do you anticipate? How will you protect yourself and your crew?

#3 You have been assigned to trim trees with an aerial lift along a power line next to a rural two-lane highway. You have never been assigned to this area before. In regard to rollovers, what hazards or problems do you anticipate? How will you protect yourself and your crew?

#1 You have been assigned to trim trees in a new area. You have been told the trees are “hard to reach.” In regard to falling from the lift, what problems do you anticipate? How will you protect yourself?

#2 You have been assigned to trim trees on a day when there is a chance of gusty winds. In regard to falling from the lift, what problems do you anticipate? How will you protect yourself?

#3 You are in charge of a work crew that is trimming storm-damaged trees in a residential area. How will you protect your crew and residents from falling limbs while you work?

#1 Your crew is heading out for what you expect to be a long, hard day. The forecast calls for hot and humid weather. One of your crew members is new, and has been working less than a week. What issues do you need to consider and what precaution should you take to protect the crew from the heat and sun?

#2 Your crew has been working hard all day. The weather is hot and sunny. A crew member says he feels ill. His skin is pale and sweaty and he is sick to his stomach.

- a) What actions do you take?**
- b) Despite your efforts, your crew member begins acting disoriented. His skin turns red, hot and dry. Now what actions do you take?**

#3 You are trimming isolated trees next to a power line in a lakeside picnic area. The sky looks stormy and dark. You think you see a flash of lightning on the horizon, but you can't hear any thunder.

- a) What actions do you take?**
- b) Suddenly, lightning flashes nearby. You have your aerial lift truck. There is also an open shelter house and a dry culvert under the road. Now what actions do you take?**

- 1. Which of the following is the most serious safety message?**
 - a. Danger**
 - b. Warning**
 - c. Caution**

- 2. You are required to use a lanyard and a body belt or harness when working in the bucket of an aerial lift.**
True/False

- 3. Which is the best practice when setting up an aerial lift at a job site?**
 - a. Use outriggers and make sure the lift is stable.**
 - b. Set up the lift on soft, muddy ground.**
 - c. If your lift is insulated, cover the surface of the boom with a light coating of grease.**

- 4. Do not perform maintenance beneath a raised boom unless it is supported by:**
 - a. a concrete block.**
 - b. an approved support device.**
 - c. a jack.**

- 5. Which of the following practices is the safest for a worker in the bucket?**
 - a. If the boom acts sluggish, try popping and jerking the controls.**
 - b. The operator on the ground should get permission from the worker in the bucket before using the lower controls.**
 - c. When it is windy, the worker in the bucket should attach one end of the lanyard to the safety belt and the other to a nearby tree or pole.**

6. Which of the following will help you avoid overturning the lift?

- a. Park away from the work and reach as far as possible with the boom.**
- b. Operate the lift controls as rapidly as possible.**
- c. Completely lower and secure the boom before moving the truck.**

7. Which is the best practice when lifting a load?

- a. Check the operator's manual for lifting capacity and procedures.**
- b. Position a worker under the load to give hand signals to the operator.**
- c. Once the load is in the air, swing it rapidly into position.**

- 8. You need to trim a high branch, but the lift will not reach. Which of the following is safer?**
- a. Set up a ladder in the bucket.**
 - b. Use a pole saw while standing on the floor of the bucket.**
 - c. Attach your lanyard to the tree and stand on top of the bucket.**
- 9. Which is the best practice when cutting limbs?**
- a. The worker in the bucket should drop limbs to workers waiting on the ground.**
 - b. The worker in the bucket should lower limbs by hand to workers on the ground.**
 - c. Workers on the ground should stay away while the boom is raised.**

- 10. Workers must keep their distance from energized power lines. How far away must an unqualified worker be at all times?**
- a. At least 3 feet, depending on voltage.**
 - b. At least 7 feet, depending on voltage.**
 - c. At least 10 feet, depending on voltage.**
- 11. Which of the following is the best practice when working around power lines?**
- a. Keep enough distance to allow for sway of the boom and lines.**
 - b. Drill extra holes in the bucket to reduce the wind resistance.**
 - c. Make sure workers on the ground stand close to the lift.**

- 12. Prevent skin cancer by covering exposed skin with a broad spectrum sunscreen that has a Sun Protection Factor (SPF) of at least:**
- a. 5**
 - b. 10**
 - c. 15**
- 13. When working in the heat, how much water should you drink to avoid heat illness?**
- a. 1 cup per hour.**
 - b. 1 quart per hour.**
 - c. 1 gallon per hour.**
- 14. Use _____ to stop bleeding from minor cuts.**
- a. a tourniquet**
 - b. direct pressure**
 - c. warm water**

15. When a worker is elevated in the bucket, the lower controls should only be used with the permission of the elevated worker or in case of an emergency.

True/False

Answer Key

Aerial Lift Safety Conclusion

1. a

2. T

3. a

4. b

5. b

6. c

7. a

8. b

9. c

10. c

11. a

12. c

13. b

14. b

15. T

Daily Pre-Operation Inspection: Aerial Lift

Operator: _____ Date: _____

Aerial Lift ID: _____

Location: _____

Item	OK	Needs Attention	Comments
Work Site <ul style="list-style-type: none"> ● Clear of other vehicles ● Clear of unauthorized people ● Safe distance from ditches, drop offs and embankments ● Safe distance from overhead obstructions and power lines 			
Machine Placement <ul style="list-style-type: none"> ● Level surface ● Solid surface or outrigger pads used ● Surface slope not greater than manufacturer's recommendations 			
Tires <ul style="list-style-type: none"> ● Proper inflation ● No visible damage ● Lug bolts tight 			
Outriggers <ul style="list-style-type: none"> ● No damage ● No missing parts 			
Controls <ul style="list-style-type: none"> ● Tested according to manufacturer's directions 			
Boom <ul style="list-style-type: none"> ● No structural damage ● No cracks or damaged connectors ● Clean and dry 			
Hydraulic System <ul style="list-style-type: none"> ● Fluid level ok ● No leaks 			
Brakes <ul style="list-style-type: none"> ● Tested according to manufacturer's directions 			
Safety Devices <ul style="list-style-type: none"> ● All guards in place ● Lights, alarms and interlocks tested 			

Operator Performance Evaluation: Aerial Lift

Operator: _____ Date: _____

Instructor: _____ Location: _____

	Satisfactory	Needs Improvement
Follows Pre-Operation Inspection		
Safe Start Up		
● Clear the area of bystanders		
● Wear hearing protection, as necessary		
● Dress appropriately		
● Determine if powerline precautions are required		
● Vehicle is positioned on level ground		
● Set the parking brake		
● Chock the wheels		
● Engage power supply		
● Set the outriggers		
● Make sure vehicle is stable before entering bucket/platform and raising and lowering the platform.		
● Follow additional procedures in operator's manual		
Safe Maneuvering		
● Doesn't endanger people or property		
● Operates equipment according to manufacturer's instructions		
● Avoid jerking controls		
● Avoid obstacles		
● Avoid potential crush points		
Safe Shut-down		
● Slowly lower boom to rest on supports		
● Secure the boom according to operator's manual		
● Raise the outriggers		
● Shut off power supply		
● Depress parking brake		
● Remove outrigger pads (if applicable) and wheel chocks		
● Follow additional procedure in operator's manual		

Mowing and Trimming Safety Training Guide

Suggested Materials

- Mowing and Trimming Safety* (English, MF2714; Spanish, MF2714S)
- Sign-in sheet
- Pencils
- Instructor guide
- Training overheads/slides/projector
- Blank overheads/flipchart/blackboard/pen for listing participant responses and outlining important concepts
- Trailer for loading mower for hands-on exercises
- Mowing and trimming equipment for hands-on exercises
- Power cords and electrical tools appropriate for hands-on exercises
- Traffic control devices for hands-on exercises
- Ear plugs and other protective equipment for hands-on exercises
- First aid kits for hands-on exercises

Sources of Background Information

Mowing and trimming, tractor safety and motor vehicle manuals available for download:

http://www.ksre.ksu.edu/library/landscaping_equipment_safety.htm

Outdoor Power Equipment Institute safety brochures: *<http://www.opei.org/>*

Operator's manuals for mowing and trimming equipment (available from dealer)

Length of Time Needed for Training

Review and select the learning activities that are most appropriate. If all of the discussion and hands-on exercises are included in the training it may take up to a full work day. Without the hands-on exercises, the classroom portion will take about two hours.

Welcome and Introduction

- ▶ Introduce yourself.
- ▶ Remind participants of the topic of the training.
- ▶ Discuss exit locations, emergency procedures, breaks, locations of restrooms, ending time and any tests or evaluations.
- ▶ Tell participants you expect them to play an active role by relating their experiences and knowledge.

Participant Introductions

Find out:

- ▶ Who are they?
- ▶ What is their experience with mowing and trimming?
- ▶ What do they hope to learn from the training?

Questioning/Discussion

Before beginning Lesson 1:

- ▶ What do participants think are the most common types of accidents that happen when mowing and trimming? List ideas on an overhead or flipchart.
- ▶ Have any participants known someone who has been killed or seriously injured while mowing or trimming? Would anyone care to share what happened?

Lesson 1

Take Control of Your Own Safety

Suggested Objectives

- Name the most common types of serious accidents involving mowers and trimmers.
- Interpret the meaning of common warning signs and labels.
- Identify appropriate protective equipment.

Discuss Accident Reports on page 4 of *Mowing and Trimming Safety*.

- ▶ How well did participants' ideas for the most common cause of accidents match those in *Mowing and Trimming Safety*? (Refer to the overhead or flipchart list made during the introduction.)
- ▶ Which of these hazards represents the greatest risk in your workplace?

Hands-on Exercise

- ▶ Break the class into groups of three to five participants. Have each group look for safety messages and signs on the mowing and trimming equipment they commonly use. Bring the class together and ask each group to report on what they saw.
- ▶ Have participants inspect and wear any protective equipment that is required for their work. Discuss the importance of each item.

Try on hearing protection:

- ▶ follow manufacturer's procedure or use the general procedure below.
- ▶ demonstrate technique.
- ▶ provide feedback as participants practice.

Types of Hearing Protection:

Ear Plugs



- ▶ Clean hands.
- ▶ Roll ear plug between fingers to compress it.
- ▶ Grasp ear from behind your head with opposite hand and pull up to straighten ear canal.
- ▶ Insert ear plug until it blocks sound, then hold in place while it expands. (Count out loud to 20 while it expands.)
- ▶ Ear plug must completely fill ear canal.
- ▶ Test fit by cupping hands over ears and then releasing. There should not be much difference in sound.
- ▶ Wash reusable plugs in warm soapy water after use/throw away disposable after each use.

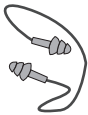

Hearing Bands



- ▶ Grasp ear from behind your head with opposite hand and pull up to straighten ear canal.
- ▶ Use your hands to press the ear pads into the ear canals.
- ▶ Test fit in a noisy environment: Lightly press band inward and you should not notice much reduction in noise level.

Ear Muffs



- ▶ Make sure the cushions fully cover the ear and seal tightly against the head.
- ▶ Hold the headband at the crown of the head and adjust each cup.
- ▶ Test fit in a noisy environment: Gently push the cups toward your head and release. There should not be much difference in noise level.



Inserting Ear Plugs

Discuss Accident Reports on page 7 of *Mowing and Trimming Safety*.

Evaluation

As a group, answer the quiz items on page 8 of *Mowing and Trimming Safety*. Be sure to discuss each item.

Questioning

Before beginning Lesson 2:

- ▶ What specific safety items do participants check in regard to their equipment and worksite before beginning each job?
- ▶ What precautions do they take when they shut down their mowing equipment and leave it unattended?

Lesson 2

Prepare for Safe Operation

Suggested Objectives

- Indicate mower parts to be inspected before operation.
- Identify steps to prepare the area for safe mowing.
- Recognize safe start up and shut down procedures.

Discuss the Pre-Start Inspection and Prepare the Mowing Area on pages 9-11 of *Mowing and Trimming Safety*.

- ▶ How do participants' current pre-operation inspections compare to the one listed in their manual? (Refer to the overhead or flipchart list made during the Lesson 1.)
- ▶ What is the company's policy for recording pre-start equipment checks?
- ▶ Are appropriate safety guards and interlocks present and functional on all of your company's mowing and trimming equipment? What is your company's procedure for reporting and repairing damaged equipment?
- ▶ Discuss the company's policy for using safety belts on riding mowers and tractors.

Discuss the Accident Report on page 12 of *Mowing and Trimming Safety*.

Analysis

Ask participants to silently read "Safe Start Up and Shut Down" on page 12 of *Mowing and Trimming Safety*. For each item, ask participants to write in the margin to indicate if the item mainly protects them from "being caught in or struck by moving parts," "being run over," or "other hazards." When everyone has finished, have each participant read an item in turn and briefly tell what type of accident it will prevent and why. Be sure to discuss items that participants find surprising or hard to comply with.

Visual Aid

- ▶ Discuss the overhead/slide entitled, "Is This a Good Idea?" on page 212 of the Instructor Guide. Ask participants to identify all safety problems indicated in the story.
- ▶ Discuss how the worker could have handled the situation in a better manner.
- ▶ Discuss any points from "Safe Fueling Procedures" that haven't been mentioned.

Discuss the Accident Reports on page 13 of *Mowing and Trimming Safety*.

- ▶ Discuss the company's policy for ventilating the repair shop while working on equipment with the engine running.

Evaluation

Ask participants to answer the quiz items on page 13 of *Mowing and Trimming Safety*. Be sure to discuss each item.

Hands-on Exercises

Demonstrate and have participants practice the following skills:

- ▶ Inspect mowing/trimming equipment using the Daily Pre-Operation Inspection on page 225 of the Instructor Guide or other checklist used by the company (can be done as a group or individually).
- ▶ Safely start and shut down mowing/trimming equipment observing the precautions in Lesson 2 of *Mowing and Trimming Safety*. Before beginning instruct all participants about important operating controls and keep other participants out of the way.
- ▶ Discuss startup and shutdown procedures that are relevant for other types of equipment.

Lesson 3

Preventing Rollover Accidents

Suggested Objectives

- Recognize safe operating procedures to prevent a rollover accident.
- Identify issues of concern when mowing on slopes.

Discuss Accident Report on page 15 of *Mowing and Trimming Safety*.

Case Studies

Break the class into small groups of three to five participants. Provide each group with one of the scenarios on pages 213-215 of this Instructor Guide. Ask each group to discuss their scenario, using the information from Lesson 3 of *Mowing and Trimming Safety*. If there are more than three groups, more than one group can work on the same scenario. Monitor the progress of each group. Bring the class back together and ask for a representative from each group to read their problem and explain their solution. Display case study overheads as each group takes turns. Ask other groups what they think of the proposed solution.

Evaluation

Answer the quiz items on page 17 of *Mowing and Trimming Safety* individually or as a class. Be sure to discuss each item.

Avoid Being Caught in Moving Parts

Suggested Objectives

- Recognize safe operating procedures to avoid being caught in moving parts.
- Identify hazards associated with equipment parts.

Discuss Accident Reports on pages 18-20 of *Mowing and Trimming Safety*.

- ▶ Have participants known of workers who have been seriously hurt by moving parts in any other ways? Would anyone care to share what happened?

Analysis

Ask each participant to silently read the recommendations on pages 18-20 of *Mowing and Trimming Safety* and circle the item that s/he believes would prevent the most injuries in your company given the equipment that is used, the jobs that are performed and any problems that have occurred in the past. Ask a few volunteers to discuss their selections.

Discussion

Discuss your company's policies regarding the following:

- ▶ maintaining guards and shields.
- ▶ adding blades and chains that are not recommended by the manufacturer.
- ▶ shutting down equipment before unclogging or making adjustments.

Evaluation

Answer the quiz items on page 21 of *Mowing and Trimming Safety* individually or as a class. Be sure to discuss each item.

Hands-on Exercise

Break the class into groups of three to five participants. Ask each group to evaluate one item of mowing or trimming equipment and report back to the class regarding whether guards are in place and operating properly, and any precautions that are necessary in order to prevent contact with hazardous parts.

Lesson 4

Lesson 5

Other Common Dangers

Suggested Objectives

- Identify steps to avoid being run over.
- Become aware of hitching and unhitching procedures.
- List precautions to avoid hitting obstacles.
- Recognize how to prevent objects from being thrown during equipment operation.
- Evaluate how to safely operate equipment in and around traffic.
- Become aware of electrical hazards.

Discuss Accident Reports on pages 23 and 24 of *Mowing and Trimming Safety*.

Analysis

For each item listed in “Runovers” on page 22 of *Mowing and Trimming Safety*, read the item and ask a participant to briefly describe:

- ▶ How could someone be killed or injured if they don’t follow the recommendations?
- ▶ Given the kinds of projects participants work on, when is a runover most likely to occur?
- ▶ Ask participants to silently read “Hitching and Unhitching Attachments” on page 22 of *Mowing and Trimming Safety*. For each item, ask participants to write “rollover,” “runover,” “moving parts,” or “multiple hazards” in the margin next to each item to identify the type of accident that could happen if they don’t follow the recommendation. When everyone has finished, have each participant read an item, briefly tell what type of accident it will prevent and why. Be sure to discuss items that participants find surprising or hard to comply with.
- ▶ Ask participants to silently read “Obstacles” on page 23 of *Mowing and Trimming Safety*. In the margin next to each item, ask participants to write an example they have recently seen or experienced. When finished, ask volunteers to quickly describe one of the examples they recorded and discuss how they would deal with it.
- ▶ As a group, read “Thrown Objects” on page 24 of *Mowing and Trimming Safety*. For each item, call on a participant to describe a situation when it is a hard to comply with the recommendation. What can be done to make compliance easier?

Hands-on Exercises

- ▶ In a safe area such as a private road or parking lot on your company's property, have participants set up a roadside work area using traffic cones and flaggers, as appropriate. Make sure all participants wear brightly-colored reflective vests and any other safety equipment that your company requires for this type of work. Guidelines for roadside work areas are detailed in the Motor Vehicle Safety Manual for Landscaping and Horticultural Services (http://www.ksre.ksu.edu/ag-safe/training/OSHA_training.htm)
- ▶ In a safe area with adequate supervision, have participants practice loading mowers safely onto a trailer.
- ▶ Break the class into groups of three to five participants. Ask each group to inspect familiar power cords and electrical tools. Is there any damage to the item? Is it rated for outdoor use? Is it safe to use in a damp or wet area? Ask each group to report on one or more items. Do other groups agree with their assessment? Should any items be taken out of service?
- ▶ Ask participants to look at the electrical outlets on the outside of the building. Are there any GFCIs? If not, how can GFCI protection be obtained? Discuss the benefits and limitations of GFCIs.
- ▶ Take the class outdoors and point out several distinct areas for mowing and trimming nearby. Break the class into groups of three to five participants. Ask each group to evaluate one of the areas and report back to the class regarding any hazards they observed and precautions that are necessary in order to prevent accidents involving rollovers, runovers, collisions, power lines, thrown objects and traffic.

Evaluation

Answer the quiz items on page 26 of *Mowing and Trimming Safety* individually or as a class. Be sure to discuss each item.

Lesson 6

Environmental Hazards

Suggested Objectives

- Identify environmental hazards.
- Recognize treatment and first aid for exposure to environmental hazards.

Discuss Accident Reports on pages 29 and 32 of *Mowing and Trimming Safety*.

Contest

Divide the class into groups. Display the contest items provided on pages 216-220 of the Instructor Guide. In turn, ask each group a multiple choice or true/false question. Each group gets one point for every correct answer. If a group misses a question, allow the next group to answer it for a point. Keep track of points and recognize the winning group. Use the questions as opportunities to discuss the training material. If possible, use an overhead or slide projector to display each question as you ask it. Answer key is provided on page 221 of the Instructor Guide.

Hands-on Exercise

Using the company's first aid kits, demonstrate and have participants practice first aid for cuts, burns, heat exhaustion, cold injury and lightning strike.

Evaluation

Answer the quiz items on page 33 of *Mowing and Trimming Safety* either individually or as a class. Be sure to discuss each item.

Conclusion

Case Studies

Break the class into small groups of three to five participants. Provide each group with one of the scenarios on pages 222-224 of this Instructor Guide. Ask each group to discuss their scenario, using the information in the Mowing and Trimming Safety Manual. If there are more than three groups, more than one group can work on the same scenario. Monitor the progress of each group. Bring the class back together and ask for a representative from each group to read their problem and explain their solution. Display case study overheads as each group takes turns. Ask other groups what they think of the proposed solution.

Discussion

Ask participants to share any questions or concerns they may still have or want to discuss further.

Evaluation

Answer the quiz questions on page 35 of *Mowing and Trimming Safety*, individually or as a group. Be sure to discuss each item.

Hands-on Performance Evaluation

In a safe area with adequate supervision, have each participant complete a hands-on performance evaluation. The evaluation may include the use of the Pre-Operation Inspection provided on page 225 of the Instructor Guide and proper use of mowing and trimming equipment.

A checklist for the performance evaluation is on page 226 of the Instructor Guide.

Is This a Good Idea?

It was getting late and a worker was hurrying to finish his mowing job. His fuel was low, so he stopped his riding mower and hopped off with the engine still running. With a lit cigar clenched between his teeth, he opened the cap on the mower's fuel tank. He grabbed the gas can and took off the lid. He didn't have time to attach the fill spout, so he poured the gasoline "free-hand" into the tank.

#1 You are in charge of a work crew assigned to mow a large park. Your equipment includes riding mowers, push mowers and string trimmers. Your crew consists of two experienced workers and a new 18-year-old employee. This is the first time your crew has been to this park. In regard to rollovers, what hazardous areas do you expect to find when you get there? How will you assign your equipment and crew in light of those hazards?

#2 You are assigned to mow a large commercial property. The area includes a large grassy area with an artificial pond and fountain. It also includes an asphalt parking lot with many grassy islands. Finally, there is a steep roadside ditch. What issues do you need to consider, what equipment will you use, and what precautions should you take to avoid rollover accidents while operating here?

#3 You are visiting an old cemetery to prepare a bid for mowing it. As you estimate the time and equipment you will need, what hazards should you look for, and what issues should you consider regarding rollover accidents?

1. Use direct pressure to:

- a. stop bleeding from minor cuts.**
- b. treat a burn.**
- c. neither A nor B.**

2. Use cool water to treat:

- a. hypothermia.**
- b. a minor burn.**
- c. neither A nor B.**

3. Seek medical attention if:

- a. direct pressure will not stop a cut from bleeding.**
- b. burns occur on the face or genitals.**
- c. both A and B.**

- 4. Light headedness, dizziness, and clammy, moist skin are most likely to be signs of:**
 - a. heat stroke.**
 - b. heat exhaustion.**
 - c. heat rash.**

- 5. Disorientation, confusion, and hot, dry, red skin are likely signs of:**
 - a. heat stroke.**
 - b. heat exhaustion.**
 - c. neither A nor B.**

- 6. Which of the following is a medical emergency that can quickly result in death:**
 - a. heat stroke.**
 - b. heat exhaustion.**
 - c. heat rash.**

7. Which of the following is the best practice for avoiding heat illness?

- a. Drink plenty of soda, tea or coffee.**
- b. Eat large meals before working.**
- c. Drink at least a quart of water per hour.**

8. Treat heat exhaustion by:

- a. covering the person with a warm blanket.**
- b. moving the person to a cool area and giving them fluids to drink.**
- c. giving the person salt tablets.**

9. Prolonged exposure to sunlight can cause:

- a. skin cancer.**
- b. cataracts.**
- c. both A and B.**

- 10. You can help prevent skin cancer by using a broad spectrum sunscreen with a Sun Protection Factor (SPF) of at least 15. A broad spectrum sunscreen will help protect you from:**
- a. UVA rays.**
 - b. UVB rays.**
 - c. both A and B.**
- 11. Frozen skin and tissue is known as:**
- a. hypothermia.**
 - b. frostbite.**
 - c. neither A nor B.**
- 12. When a person's core body temperature drops to 95 degrees F or below, the condition is known as:**
- a. hypothermia.**
 - b. frostbite.**
 - c. neither A nor B.**

13. Treat a cold-induced injury by:

- a. making the person warm and dry, and seeing medical attention immediately.**
- b. rubbing any numb, white skin.**
- c. giving the person alcoholic beverages to drink.**

14. Which of the following is the best practice?

- a. Treat a poisonous snake bite by cutting an X on each fang mark and sucking out the poison.**
- b. Treat a minor insect sting by removing the stinger and applying ice.**
- c. Treat minor cuts by applying a tourniquet.**

15. Which of the following provides the BEST protection against lightning?

- a. Crouch in a ditch.**
- b. Get inside an enclosed vehicle.**
- c. Get inside a sturdy building.**

Answer Key

Mowing and Trimming Safety Lesson 6

1. a

2. b

3. c

4. b

5. a

6. a

7. c

8. b

9. c

10. c

11. b

12. a

13. a

14. b

15. c

#1 You have been assigned to mow a public playground. Describe all of the hazards you will consider as you plan your work. What precautions will you take to protect yourself and others?

#2 You have been assigned to mow a ditch along a busy road. Describe all of the hazards you will consider as you plan your work. What precautions will you take to protect yourself and others?

#3 You have been assigned to mow a popular camping and picnic area at a lake during the summer. Describe all of the hazards you will consider as you plan your work. What precautions will you take to protect yourself and others?

Daily Pre-Operation Inspection: Mower/Trimmer

Operator: _____ Date: _____

Mower/Trimmer ID: _____

Location: _____

Item	OK	Needs Attention	Comments
Belts <ul style="list-style-type: none"> ● Secure ● Not cracked or separated 			
Blade <ul style="list-style-type: none"> ● Secure and balanced ● Sharpened ● Free of excessive wear 			
Fluid Leaks <ul style="list-style-type: none"> ● No sign of fluid leaks 			
Accumulated Grass/Grease <ul style="list-style-type: none"> ● Mower, deck and chute free of debris 			
Guards <ul style="list-style-type: none"> ● All guards in place ● No sign of damage 			
Tires <ul style="list-style-type: none"> ● Proper inflation ● No visible damage ● Lug bolts tight 			
Attachments(if applicable) <ul style="list-style-type: none"> ● Mounted and secured properly 			
String/Brush Trimmer <ul style="list-style-type: none"> ● String/blade attached properly ● String/blade shield in place and secured 			
Protective Clothing/Equipment (as needed) <ul style="list-style-type: none"> ● Long pants ● Sturdy, non-slip boots ● No loose clothing or jewelry ● Hearing protection ● Eye protection ● Face protection 			

Operator Performance Evaluation: Mower/Trimmer

Operator: _____ Date: _____

Mower/Trimmer ID: _____ Make/Model: _____

Instructor: _____ Location: _____

	Satisfactory	Needs Improvement
Follows Pre-Operation Inspection		
Prepares Mowing area		
● Removes debris		
● Bystanders out of the way		
Safe Start Up		
● Wears personal protective equipment, including hearing and eye protection, as necessary.		
● Attachments are disengaged		
● Shifts into neutral before starting the engine		
● Controls in neutral and parking brake set		
● Always starts string/brush trimmers on the ground		
● Starts riding equipment from the operator's seat only		
● Keeps hands and feet away from the blade area when starting walk-behind mowers		
Safe Operation		
● Doesn't endanger people or property		
● Operates equipment according to manufacturer's instructions		
● Operates appropriately on hills		
● Avoids hazardous areas		
● Turns appropriately		
Safe Shut Down and Exit		
● Disengage the blade and other attachments		
● Lower the attachments to the ground		
● Shift the controls into neutral		
● Set the parking brake		
● Turn the engine off		
● Remove the key (if applicable)		

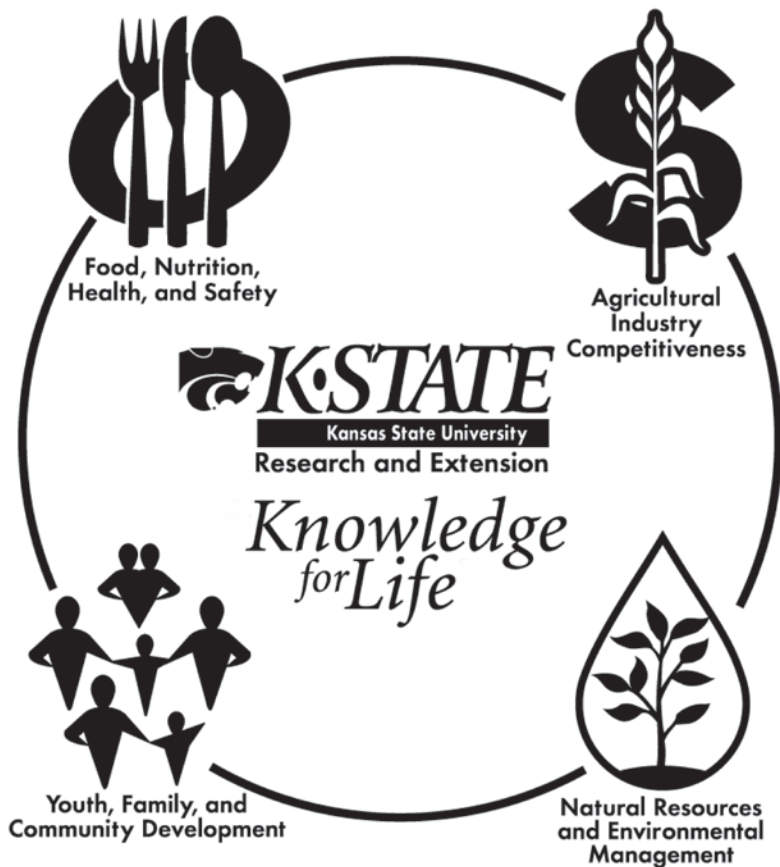

This publication is produced by K-State Research and Extension, Manhattan, Kansas, www.ksre.ksu.edu

Brand names appearing in this publication are for product identification purposes only. No endorsement is intended, nor is criticism implied of similar products not mentioned.

Kansas State University Agricultural Experiment Station and Cooperative Extension Service

MF 2716 rev.

October 2009

K-State Research and Extension is an equal opportunity provider and employer. Issued in furtherance of Cooperative Extension Work, Acts of May 8 and June 30, 1914, as amended. Kansas State University, County Extension Councils, Extension Districts, and United States Department of Agriculture Cooperating, Fred A. Cholick, Director.